



**Oil Conserving Fryer (OCCF30)TM
Electric Series Fryers
Service & Parts Manual**



Frymaster, a member of the Commercial Food Equipment Service Association, recommends using CFESA Certified Technicians.

24-Hour Service Hotline 1-800-551-8633

www.frymaster.com

E-mail: service@frymaster.com

MARCH 2012
* 8196686 *

NOTICE

IF, DURING THE WARRANTY PERIOD, THE CUSTOMER USES A PART FOR THIS MANITOWOC FOOD SERVICE EQUIPMENT OTHER THAN AN UNMODIFIED NEW OR RECYCLED PART PURCHASED DIRECTLY FROM FRYMASTER DEAN, OR ANY OF ITS FACTORY AUTHORIZED SERVICERS, AND/OR THE PART BEING USED IS MODIFIED FROM ITS ORIGINAL CONFIGURATION, THIS WARRANTY WILL BE VOID. FURTHER, FRYMASTER DEAN AND ITS AFFILIATES WILL NOT BE LIABLE FOR ANY CLAIMS, DAMAGES OR EXPENSES INCURRED BY THE CUSTOMER WHICH ARISE DIRECTLY OR INDIRECTLY, IN WHOLE OR IN PART, DUE TO THE INSTALLATION OF ANY MODIFIED PART AND/OR PART RECEIVED FROM AN UNAUTHORIZED SERVICE CENTER.

⚠ DANGER

Copper wire suitable for at least 167°F (75°C) must be used for power connections.

⚠ DANGER

The electrical power supply for this appliance must be the same as indicated on the rating and serial number plate located on the inside of the fryer door.

⚠ DANGER

This appliance must be connected to the voltage and phase as specified on the rating and serial number plate located on the inside of the fryer door.

⚠ DANGER

All wiring connections for this appliance must be made in accordance with the wiring diagrams furnished with the equipment. Wiring diagrams are located on the inside of the fryer door.

⚠ DANGER

Do not store or use gasoline or other flammable vapors and liquids in the vicinity of this or any other appliance.

⚠ WARNING

Do not attach accessories to this fryer unless fryer is secured from tipping. Personal injury may result.

⚠ WARNING

Frymaster fryers equipped with legs are for permanent installations. Fryers fitted with legs must be lifted during movement to avoid damage and possible bodily injury. For a moveable or portable installation, Frymaster optional equipment casters must be used. Questions? Call 1-800-551-8633 or email at service@frymaster.com.

⚠ WARNING

Do not use water jets to clean this equipment.

⚠ WARNING

This equipment is intended for indoor use only. Do not install or operate this equipment in outdoor areas.

⚠ DANGER

Adequate means must be provided to limit the movement of this appliance without depending on or transmitting stress to the electrical conduit. A restraint kit is provided with the fryer. If the restraint kit is missing contact your local KES.

⚠ DANGER

Prior to movement, testing, maintenance and any repair on your Frymaster fryer, disconnect all electrical power from the fryer.

ELECTRICAL POWER SPECIFICATIONS

Three (3) Phase Requirements								
kW	VOLTAGE	PHASE	WIRE SERVICE	MINIMUM SIZE		AMPS PER LEG		
				AWG	mm ²	L1	L2	L3
14	208	3	3	6	16	39	39	39
14	240	3	3	6	16	34	34	34
14	480	3	3	8	10	17	17	17
14	220/380	3	4	6	16	21	21	21
14	240/415	3	4	6	16	20	20	21
14	230/400	3	4	6	16	21	21	21
17	208	3	3	6	16	48	48	48
17	240	3	3	6	16	41	41	41
17	480	3	3	6	16	21	21	21
17	220/380	3	4	6	16	26	26	26
17	240/415	3	4	6	16	24	24	24
17	230/400	3	4	6	16	25	25	25



OCF30™ SERIES ELECTRIC FRYERS TABLE OF CONTENTS

CAUTIONARY STATEMENTS	i
ELECTRICAL POWER SPECIFICATIONS	ii
CHAPTER 1: Service Procedures	
1.1 General	1-1
1.2 Replacing a Controller	1-1
1.3 Replacing Component Box Components	1-1
1.4 Replacing a High-Limit Thermostat	1-3
1.5 Replacing a Temperature Probe	1-3
1.6 Replacing a Heating Element	1-5
1.7 Replacing Contactor Box Components	1-6
1.8 Replacing a Frypot	1-7
1.9 Built-In Filtration System Service Procedures	1-9
1.9.1 Filtration System Problem Resolution	1-9
1.9.2 Replacing the Filter Motor, Filter Pump and Related Components	1-10
1.9.3 Replacing the Filter Transformer or Filter Relay	1-12
1.10 Basket Lift Service Procedures	1-12
1.11 ATO (Automatic Top-Off) Service Procedures	1-14
1.11.1 ATO (Automatic Top-Off) Troubleshooting)	1-15
1.11.2 Testing ATO RTD Probes	1-16
1.11.3 ATO (Automatic Top-Off) Board Pin Positions and Harnesses	1-17
1.11.4 Replacing the ATO board, ATO Pump Relay or Transformer	1-18
1.11.5 Replacing the ATO Pump	1-18
1.11.6 Replacing the ATO Solenoids	1-18
1.11.7 Control Power Reset	1-19
1.12 3000 Controller Service Procedures	1-19
1.12.1 3000 Controller Troubleshooting	1-19
1.12.2 3000 Controller Useful Codes	1-22
1.12.3 Service Required Errors	1-22
1.12.4 Error Log Codes	1-23
1.12.5 3000 Menu Summary Tree	1-24
1.12.6 3000 Controller Pin Positions and Harnesses	1-25
1.13 Loading and Updating Software	1-26
1.14 Interface Board Diagnostic Chart	1-27
1.15 Probe Resistance Chart	1-28
1.16 Wiring Diagrams	1-29
1.16.1 Basket Lift Wiring 208-250V	1-29
1.16.2 Basket Lift Wiring 100-120V	1-30
1.16.3 FPEL Simplified Wiring	1-31
1.16.4 FPEL Control Wiring Domestic w/ 3000 Controller	1-32
1.16.5 FPEL Control Wiring Domestic w/ CM3.5 Controller	1-33
1.16.6 Tilt Switch Wiring	1-34
1.16.7 Contactor Box-Delta Configuration	1-35
1.16.8 Contactor Box-WYE Configuration	1-36
1.16.9 Terminal Block Wiring	1-37
1.16.10 Simplified FPEL14/17 Full-Vat Delta Wiring	1-38
1.16.11 Simplified FPEL14/17 Dual-Vat Delta Wiring	1-39
1.16.12 Simplified FPEL14/17 Full-Vat Export WYE Wiring	1-40
1.16.13 Simplified FPEL14/17 Dual-Vat Export WYE Wiring	1-41
1.16.14 Series Data Network Flowchart	1-42
1.16.15 Shortening Melting Unit Wiring Diagram	1-43

OCF30™ SERIES ELECTRIC FRYERS

TABLE OF CONTENTS cont.

1.16.16	Bulk Oil Wiring Diagram	1-44
---------	-------------------------------	------

CHAPTER 2: Parts List

2.1	Accessories	2-1
2.2	Basket Lift Assembly and Associated Parts	2-2
2.3	Doors, Sides, Tilt Housings, Top Caps and Casters	2-4
2.4	Drain System Components	2-5
2.4.1	Drain Tube Sections and Associated Parts.....	2-5
2.4.2	Drain Valve Assembly	2-7
2.5	Electronics and Wiring Components	2-8
2.5.1	Component Boxes	2-8
2.5.2	Contactors Boxes	2-10
2.5.3	Fuse Boxes	2-11
2.5.4	Terminal Blocks	2-12
2.5.5	Heating Element Assemblies and Hardware	2-13
2.5.6	Element Tube Assemblies.....	2-15
2.5.7	Controllers.....	2-15
2.5.8	Wiring	2-16
2.5.8.1	Contactors Box Wiring Assemblies 12-Pin Dual Vat.....	2-16
2.5.8.2	Contactors Box Wiring Assemblies 12-Pin Full Vat.....	2-16
2.5.8.3	Contactors Box Wiring Assemblies 6-Pin Left Element	2-17
2.5.8.4	Contactors Box Wiring Assemblies 9-Pin Right Element	2-17
2.5.8.5	Main Wiring Harnesses.....	2-18
2.5.8.6	Component Box, Filter Pump and Basket Lift Wiring Harnesses.....	2-19
2.5.8.7	Component Box to Filter Pump Harness.....	2-19
2.5.8.8	Basket Lift Harness	2-20
2.5.8.9	Interface Board to Controller Wiring Harness 15-Pin.....	2-20
2.5.8.10	3000 and ATO Wiring Harnesses	2-20
2.6	Filtration System Components	2-21
2.7	Filter Pump, Motor and Associated Components.....	2-22
2.8	Frypot Assemblies and Associated Parts.....	2-23
2.9	Oil Return System Components	2-24
2.10	Auto Top-Off Components.....	2-25
2.10.1	JIB Basket and Automatic Top-Off Board Assembly	2-25
2.10.2	JIB Cap and Pick-up Assembly	2-25
2.10.3	ATO Pump Assembly.....	2-26
2.10.4	ATO Top-Off Manifolds	2-27
2.10.5	Shortening Melting Unit.....	2-28
2.10.6	Bulk Oil Relay Box and Switch	2-29
2.10.7	Bulk Oil Plumbing.....	2-30
2.10.8	Bulk Oil Dispose Waste Valve.....	2-31
2.11	Wiring Connectors, Pin Terminals and Power Cords.....	2-32
2.12	Fasteners.....	2-33

OCF30™ SERIES ELECTRIC FRYERS

CHAPTER 1: SERVICE PROCEDURES

1.1 General

Before performing any maintenance on your Frymaster fryer, disconnect the fryer from the electrical power supply.

WARNING

To ensure the safe and efficient operation of the fryer and hood, the electrical plug must be fully engaged and locked in its pin and sleeve socket.

When electrical wires are disconnected, it is recommended that they be marked in such a way as to facilitate re-assembly.

1.2 Replacing the Controller

1. Disconnect the fryer from the electrical power supply.
2. Open the control panel by removing the screws on the bottom of the bezel. Carefully lower the bezel.
3. Remove the two screws from the upper corners of the controller. The controller is hinged at the bottom and will swing open from the top.
4. Unplug the wiring harnesses from the connectors on the back of the controller, marking their position for reassembly, and disconnect the grounding wires from the terminals. Remove the controller by lifting it from the hinged slots in the control panel frame.



5. Install the replacement controller. Reverse steps 1 thru 4.
6. Setup the controller following the instructions on page 4-3 in the Installation and Operation manual. Setup **MUST** be performed after replacement.
7. Once setup is complete on all replaced controllers, reset all control power following the instructions in section 1.11.7 on page 1-19 to readdress the new 3000 controller. Check software version and if necessary update the software. If a software update was necessary, follow the instructions to update the software in section 1.13 on page 1-26.

1.3 Replacing Component Box Components

1. Disconnect the fryer from the electrical power supply.

2. Open the control panel by removing the screws on the bottom of the bezel. Carefully lower the bezel.
3. Remove the two screws from the upper corners of the control panel and allow the control panel to swing down.
4. Unplug the wiring harnesses and disconnect the grounding wires from the terminals on the back of the controller. Remove the control panel assembly by lifting it from the hinge slots in the control panel frame.
5. Disconnect the wiring from the component to be replaced, being sure to make a note of where each wire was connected.
6. Dismount the component to be replaced and install the new component, being sure that any required spacers, insulation, washers, etc. are in place.

NOTE: If more room to work is required, the control panel frame assembly may be removed by removing the hex-head screws, which secure it to the fryer cabinet (see illustration below). If this option is chosen, all control panel assemblies must be removed per steps 1 and 2 above. The cover plate, on the lower front of the component box, may also be removed to allow additional access if desired. *Removing the component box itself from the fryer is not recommended due to the difficulty involved in disconnecting and reconnecting the oil-return valve rods, which pass through openings in the component box.*

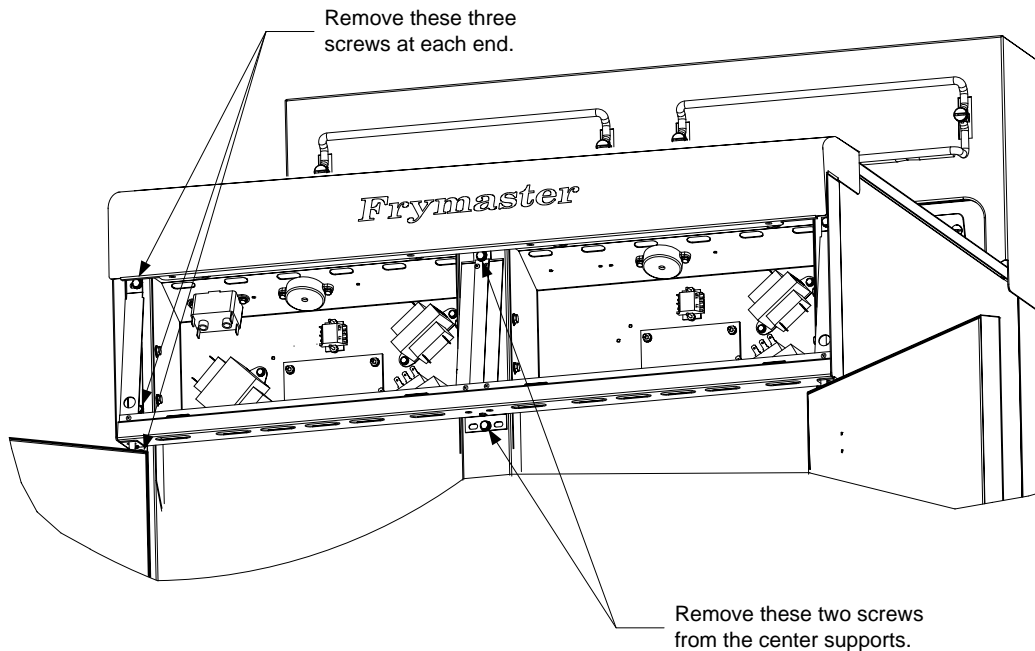

Removing the Control Panel Frame and Top Cap Assembly

7. Reconnect the wiring disconnected in step 5, referring to your notes and the wiring diagrams on the fryer door to ensure that the connections are properly made. Also, verify that no other wiring was disconnected accidentally during the replacement process.
8. Reverse steps 1 through 4 to complete the replacement and return the fryer to service.

1.4 Replacing a High-Limit Thermostat

1. Drain the frypots into a Shortening Disposal Unit (SDU) or other appropriate **METAL** container.



DANGER

DO NOT drain more than one full frypot into the SDU at one time.

2. Disconnect the fryer from the electrical power supply and reposition it to gain access to the rear of the fryer.
3. Remove the screws from the bottom of the lower back panel attaching the contactor plug guards.
4. Remove each of the guards.
5. Remove the four screws from both the left and right sides of the lower back panel.
6. Locate the high-limit that is being replaced and follow the two-black wires to the 12-pin connector C-6. Note where the leads are connected prior to removing them from the connector. Unplug the 12-pin connector C-6 and using a pin-pusher push the pins of the high-limit out of the connector.
7. Carefully unscrew the high-limit thermostat to be replaced.
8. Apply Loctite™ PST 567 or equivalent sealant to the threads of the replacement and screw it securely into the frypot.
9. Insert the leads into the 12-pin connector C-6 (see illustration below). For full-vat units or the right half of a dual-vat unit the leads go into positions 1 and 2 of the connector. For the left half of a dual-vat unit, the leads go into positions 7 and 8. In either case, polarity does not matter.

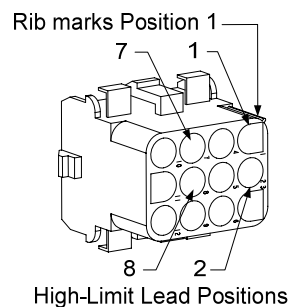

10. Reconnect the 12-pin connecting plug C-6. Use wire ties to secure any loose wires.
11. Reinstall the back panels, contactor plug guards, reposition the fryer under the exhaust hood, and reconnect it to the electrical power supply to return the fryer to service.

1.5 Replacing a Temperature Probe

1. Disconnect the fryer from the electrical power supply and reposition it to gain access to the rear of the fryer.
2. Remove each of the guards.
3. Remove the four screws from both sides of the lower back panel. Then remove the two screws on both the left and right sides of the back of the tilt housing. Lift the tilt housing straight up to remove from the fryer.

4. Locate the red and white wires of the temperature probe to be replaced. Note where the leads are connected prior to removing them from the connector. Unplug the 12-pin connector C-6 and using a pin-pusher push the pins of the temperature probe out of the connector.
5. Raise the element and remove the securing probe bracket and metal tie wraps that secure the probe to the element (see illustration below). Remove the ground clip on the probe shield.

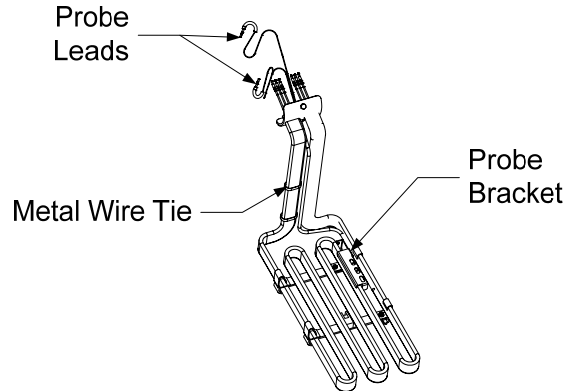

6. Gently pull on the temperature probe and grommet, pulling the wires up the rear of the fryer and through the element tube assembly.
7. Insert the replacement temperature probe (wires first) into the tube assembly ensuring that the grommet is in place. Secure the probe to the elements using the bracket which was removed in Step 5 and the metal tie wraps which were included in the replacement kit.
8. Route the probe wires out of the tube assembly following the element wires down the back of the fryer through the Heyco bushings to the 12-pin connector C-6. Secure the wires to the sheathing with wire ties. Attach the ground clip.
9. Insert the temperature probe leads into the 12-pin connector C-6 (see illustration below). For full-vat units or the right half of a dual-vat unit the red (or yellow) lead goes into position 3 and the white lead into position 4 of the connector. For the left half of a dual-vat unit, the red (or yellow) lead goes into position 9 and the white lead into position 10. **NOTE: *Right* and *left* refer to the fryer as viewed from the front.**

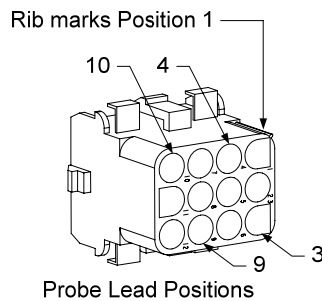

10. Secure any loose wires with wire ties, making sure there is no interference with the movement of the springs. Rotate the elements up and down, making sure movement is not restricted and that the wires are not pinched.
11. Reinstall the tilt housing, back panels and contactor plug guards. Reposition the fryer under the exhaust hood, and reconnect it to the electrical power supply to return the fryer to service.

1.6 Replacing a Heating Element

1. Perform steps 1-5 of section 1.5, *Replacing a Temperature Probe*.
2. Disconnect the wire harness containing the probe wiring. Using a pin pusher, disconnect the probe wires from the 12-pin connector C-6.
3. In the rear of the fryer, disconnect the 6-pin connector for the left element (as viewed from the front of the fryer) or the 9-pin connector for the right element from the contactor box. Press in on the tabs on each side of the connector while pulling outward on the free end to extend the connector and release the element leads (see photo below). Pull the leads out of the connector and out of the wire sleeving.

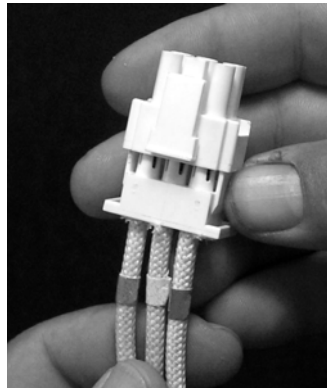

4. Raise the element to the full up position and support the elements.
5. Remove the hex head screws and nuts that secure the element to the tube assembly and pull the element out of the frypot. **NOTE:** The nuts inside the tube can be held and removed using the RE element tube nut spanner, PN# 2304028. Full-vat elements consist of two dual-vat elements clamped together. For full-vat units, remove the element clamps before removing the nuts and screws that secure the element to the tube assembly.
6. If applicable, recover the probe bracket and probe from the element being replaced and install them on the replacement element. Install the replacement element in the frypot, securing it with the nuts and screws removed in Step 5 to the tube assembly. Ensure the gasket is between the tube and element assembly.
7. Route the element leads through the element tube assembly and into the wire sleeving to prevent chafing. Ensure that the wire sleeving is routed back through the Heyco bushings, keeping it clear from the lift springs. Also ensure that the wire sleeving extends into the tube assembly, protecting the wires. Press the pins into the connector in accordance with the diagram on the following page, and then close the connector to lock the leads in place. **NOTE:** It is critical that the wires be routed through the sleeving to prevent chafing.

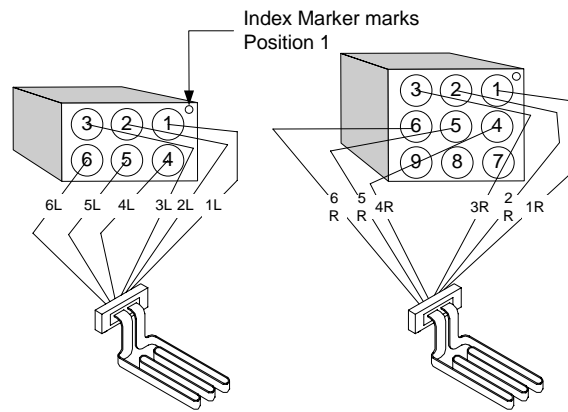

8. Reconnect the element connector ensuring that the latches lock.
9. Insert the temperature probe leads into the 12-pin wiring harness connector (see illustration below). For full-vat units or the right half of a dual-vat unit, the red lead goes into position 3 and the white into position 4. For the left half of a dual-vat unit, the red lead goes into position 9 and the white into position 10. **NOTE: *Right* and *left* refer to the fryer as viewed from the front.**

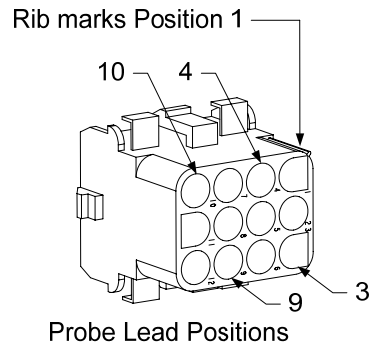

10. Reconnect the 12-pin connector C-6 of the wiring harness disconnected in Step 2.
11. Lower the element onto the basket rack.
12. Reinstall the tilt housing, back panels and contactor plug guard. Reposition the fryer under the exhaust hood, and reconnect it to the electrical power supply.

1.7 Replacing Contactor Box Components

1. If replacing a contactor box component, remove the filter pan and lid from the unit.
2. Disconnect the fryer from the electrical power supply.
3. Remove the two screws securing the cover of the contactor box. The contactor boxes above the filter pan are accessed by sliding under the fryer. They are located to the left and right above the guide rails (see photo below). The contactor boxes for frypots not over the filter pan are accessed by opening the fryer door directly under the affected frypot (see photo on following page).

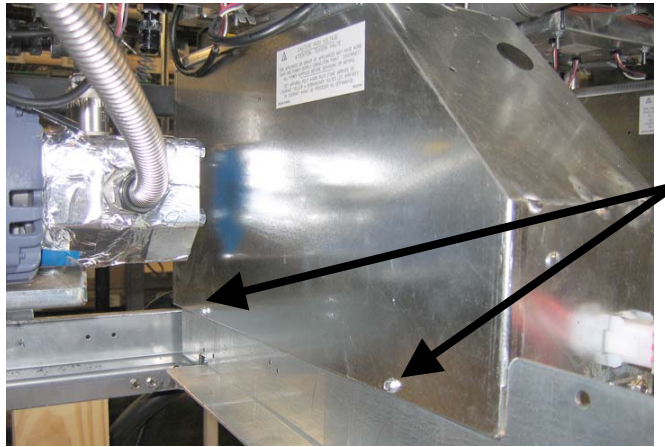

Remove two screws to access contactor box components above the filter pan.

4. The contactors and relays are held on by threaded pin studs so that only removal of the nut is required to replace the component.
5. After performing necessary service, reverse steps 1-4 to return the fryer to operation.



Left and right views of mechanical contactor box components.

1.8 Replacing a Frypot

1. Drain the frypot into the filter pan or, if replacing a frypot over the filter system, into a Shortening Disposal Unit (SDU) or other appropriate **METAL** container. If replacing a frypot over the filter system, remove the filter pan and lid from the unit.

⚠ DANGER

DO NOT drain more than one full frypot into the SDU at one time.

2. Disconnect the fryer from the electrical power supply and reposition it to gain access to both the front and rear.
3. Open the control panel by removing the two screws on the bottom of the bezel. Carefully lower the bezel.
4. Remove the two screws from the upper corners of the control panels and allow them to swing down (see photo on page 1-1).

5. Unplug the wiring harnesses and ground wires from the backs of the controllers. Remove the controllers by lifting them from the hinge slots in the control panel frame.
6. Remove the screws from the bottom of the lower back panel attaching the contactor plug guards.
7. Remove each of the guards
8. Remove the tilt housing and back panels from the fryer. The tilt housing must be removed first in order to remove the upper back panel.
9. To remove the tilt housing, remove the hex head screws from the rear edge of the housing. The housing can be lifted straight up and off the fryer.
10. Remove the control panel by removing the screws on both sides.
11. Loosen the component boxes by removing the screws, which secure them in the cabinet.
12. Remove the top cap by removing the nuts at each end that secure it to the cabinetry.
13. Remove the hex head screw that secures the front of the frypot to the cabinet cross brace.
14. Remove the top-connecting strip that covers the joint with the adjacent frypot.
15. Unscrew the nut located on the front of each section of drain tube, and remove the tube assembly from the fryer.
16. Remove the covers from the drain safety switch(es) and disconnect the wiring at the switch(es).
17. Disconnect any auto top-off sensors if equipped and wiring.
18. At the rear of the fryer, unplug the 12-pin connector C-6 and, using a pin pusher, disconnect the high-limit thermostat leads.
19. Disconnect the oil return and top off flexline(s).
20. Raise the elements to the “up” position and disconnect the element springs.
21. Remove the machine screws and nuts that secure the element tube assembly to the frypot. Carefully lift the element assembly from the frypot and secure it to the cross brace on the rear of the fryer with wire ties or tape.
22. Carefully lift the frypot from the fryer and place it upside down on a stable work surface.
23. Recover the drain valve(s), oil return flexline connection fitting(s), auto top-off sensors if equipped and high-limit thermostat(s) from the frypot. Clean the threads and apply Loctite™ PST 567 or equivalent sealant to the threads of the recovered parts and install them in the replacement frypot.
24. Carefully lower the replacement frypot into the fryer. Reinstall the hex head screw removed in step 9 to attach the frypot to the fryer.
25. Position the element tube assembly in the frypot and reinstall the machine screws and nuts removed in step 21.

26. Reconnect the oil return and auto top off flexlines to the frypot, and replace aluminum tape, if necessary, to secure heater strips to the flexlines.
27. Insert the high-limit thermostat leads disconnected in step 18 (see illustration on page 1-3 for pin positions).
28. Reconnect the auto top-off sensors.
29. Reconnect the drain safety switch wiring to the switch(es) in accordance with the diagram below then reinstall the switch covers.

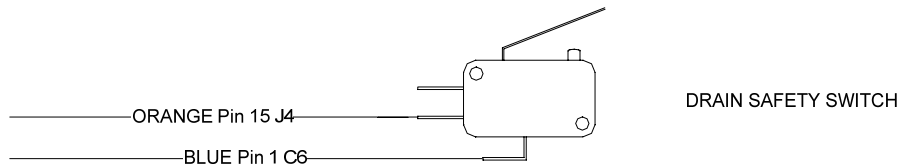

30. Reinstall the drain tube assembly.
31. Reinstall the top connecting strips, top cap, tilt housing, back panels and contactor plug guards.
32. Reinstall controllers in the control panel frame and reconnect the wiring harnesses and ground wires.
33. Reposition the fryer under the exhaust hood and reconnect it to the electrical power supply.

1.9 Built-in Filtration System Service Procedures

1.9.1 Filtration System Problem Resolution

One of the most common causes of filtration problems is placing the filter paper on the bottom of the filter pan rather than over the filter screen.

CAUTION

Ensure that filter screen is in place prior to filter paper placement and filter pump operation. Improper screen placement is the primary cause of filtration system malfunction.

Whenever the complaint is “the pump is running, but no oil is being filtered,” check the installation of the filter paper, and ensure that the correct size is being used. While you are checking the filter paper, verify that the O-rings on the pick-up tube of the filter pan are in good condition. A missing or worn O-ring allows the pump to take in air and decrease its efficiency.

If the pump motor overheats, the thermal overload will trip and the motor will not start until it is reset. If the pump motor does not start, press the red reset switch (button) located on the rear of the motor.

If the pump starts after resetting the thermal overload switch, then something is causing the motor to overheat. A major cause of overheating is when several frypots are filtered sequentially, overheating the pump and motor. Allow the pump motor to cool at least 30 minutes before resuming operation. Pump overheating can be caused by:

- Solidified shortening in the pan or filter lines, or
- Attempting to filter unheated oil or shortening (cold oil and shortening are more viscous, overloading the pump motor and causing it to overheat).

If the motor runs but the pump does not return oil, there is a blockage in the pump. Incorrectly sized or installed paper will allow food particles and sediment to pass through the filter pan and into the pump. When sediment enters the pump, the gears bind, causing the motor to overload, again tripping the thermal overload. Shortening that has solidified in the pump will also cause it to seize, with the same result.

A pump seized by debris or hard shortening can usually be freed by manually moving the gears with a screwdriver or other instrument.

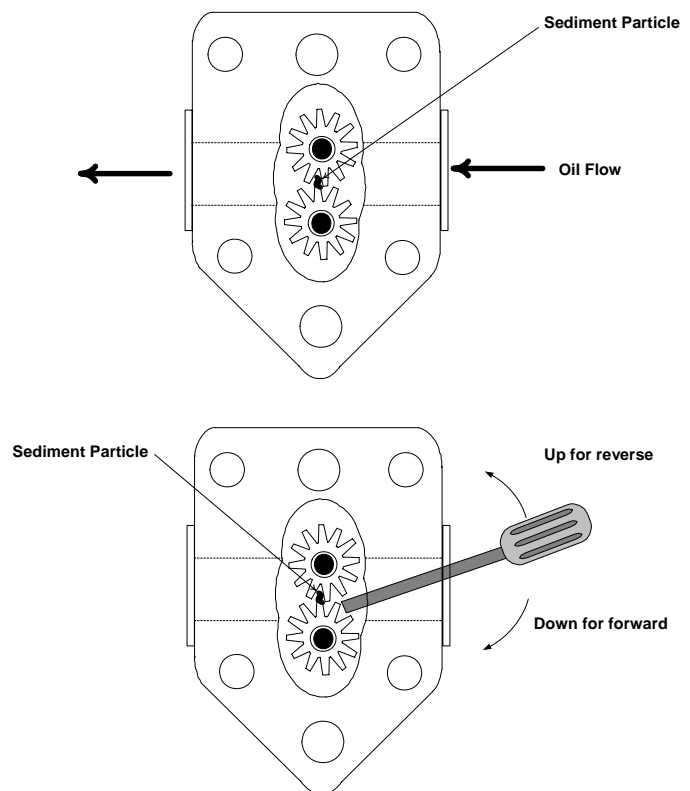

Disconnect power to the filter system, remove the input plumbing from the pump, and use a screwdriver to manually turn the gears.

- Turning the pump gears in reverse will release a hard particle.
- Turning the pump gears forward will push softer objects and solid shortening through the pump and allow free movement of the gears.

Incorrectly sized or installed paper/pads will also allow food particles and sediment to pass through and clog the suction tube on the bottom of the filter pan. Particles large enough to block the suction tube may indicate that the crumb tray is not being used. Pan blockage can also occur if shortening is left in the pan and allowed to solidify. Blockage removal can be accomplished by forcing the item out with an auger or drain snake. Compressed air or other pressurized gases should not be used to force out the blockage.

1.9.2 Replacing the Filter Motor, Filter Pump, and Related Components

1. Remove the filter pan and lid from the unit. Drain the frypots into a Shortening Disposal Unit (SDU) or other appropriate metal container.

⚠ DANGER
DO NOT drain more than one full frypot into the SDU at one time.

2. Disconnect the fryer from the electrical power supply and reposition it to gain access to both the front and rear.

3. Disconnect the flexline running to the oil-return manifold at the rear of the fryer as well as the pump suction flexline at the end of the filter pan connection (see photo below). On some models a third flexline may need to be disconnected.

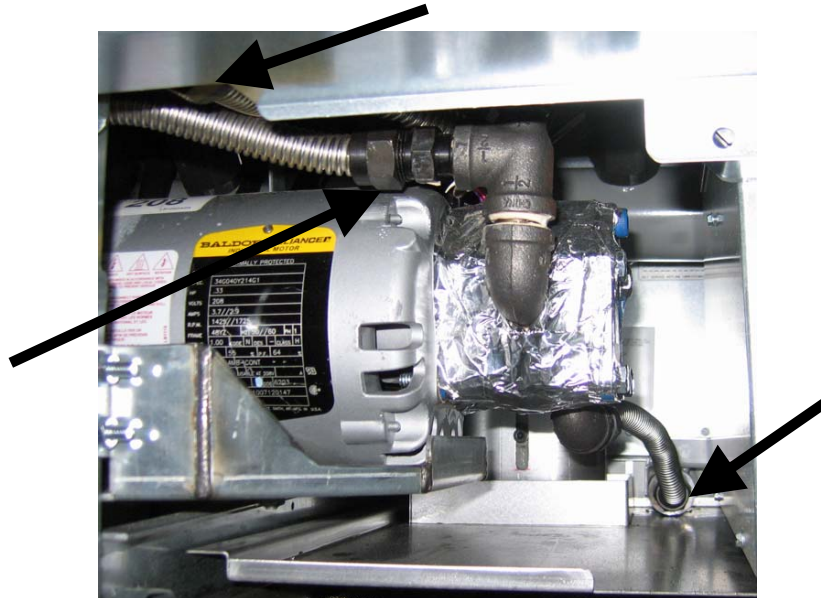

Disconnect flexlines indicated by the arrows.

4. Loosen the nut and bolt that secures the bridge to the oil-return manifold.
5. Remove the cover plate from the front of the motor and disconnect the motor wires.
6. Unplug the pump motor assembly 6-pin connector C-2.
7. Remove the two nuts and bolts which secure the front of the bridge to the cross brace and carefully slide the bridge rearward off the cross brace until its front end can be lowered to the floor. Undo the single nut holding it in place in back. Be careful not to let the rear of the bridge slip off the manifold at this point.
8. Get a good grip on the bridge, carefully pull it forward off the oil-return manifold, and lower the entire assembly to the floor. Once on the floor, pull the assembly out the front of the fryer.
9. When required service has been completed, reverse steps 3-8 to reinstall the bridge. **NOTE:** The black motor wires go on the top terminal, the white on the bottom. The red/black heater tape wires go into position 3 and the violet/white wires go into position 6 (see illustration below).

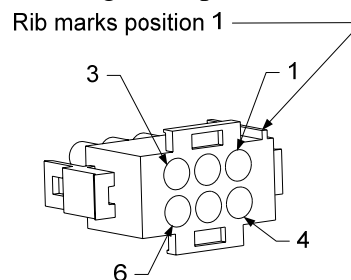

Heater Lead Positions

10. Reconnect the unit to the electrical power supply, and verify that the pump is functioning correctly (i.e., when a filter handle is placed in the ON position, the motor should start and there should be strong suction at the intake fitting and outflow at the rear flush port.)

11. When proper operation has been verified, reinstall the back panels and the filter pan and lid.
12. Reposition the fryer under the exhaust hood and reconnect it to the electrical power supply, if necessary to return the fryer to service.

1.9.3 Replacing the Transformer or Filter Relay

Disconnect the fryer from the electrical power supply. Remove the left controller from the fryer to expose the interior of the left component box. The transformer and relay on the left are located as shown in the illustration below. **NOTE:** The right component box is identical to the left except that the transformer and relay on the left side are not present. Once replaced, reconnect the power.

When replacing a filter relay in the left component box, ensure the 24VAC relay (8070670) is used on 208-240V units and 8070012 is used on 120V units. This relay is the same relay used in the RE fryers.

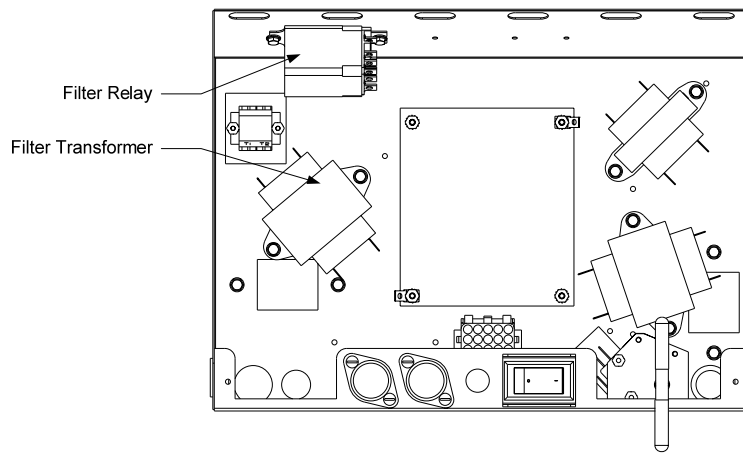

1.10 Basket Lift Service Procedures

OCF30™ Series electric fryers may be equipped with automatic basket lifts. Basket lifts always come in pairs, although each operates independently.

A **modular basket lift** (illustrated on the following page) is a self-contained sub-assembly consisting of a pair of toothed rods, which support removable basket lift arms, a pair of reversible-drive gear motors, and four microswitches. The gear motors engage the teeth of the rods, moving them up or down depending upon the motors' direction of rotation. The microswitches at the upper and lower limits of movement stop the motors when the basket is in the full up or full down position.

Timing circuitry in the controller initiates and stops basket lift operation depending upon the variables programmed by the operator. When the product button is pressed, the timing circuitry activates a coil in the basket lift relay to supply power to the lower microswitch. The microswitches stop the motor at the lift's upper and lower travel limits and reverse the direction of current flow thus reversing the motor direction.

When the product button is pushed on the controller, current flows through a coil in the basket lift relay, causing the lower circuit to be activated. The basket lift lowers, closing the normally open upper-micro-switch. When the downward-moving rod opens the lower normally closed microswitch, the power to the motor ceases to flow. When the controller times out, the current to the relay coil is cut, allowing the upper circuit to be activated. The basket lift rises and re-closes the lower

microswitch. When the basket lift rod clears the upper microswitch, the microswitch reopens, power to the circuit is cut, and the motor stops. Pushing the product button restarts the cycle.

Problems with the basket lift can be grouped into three categories:

- Binding/jamming problems
- Motor and gear problems
- Electronic problems

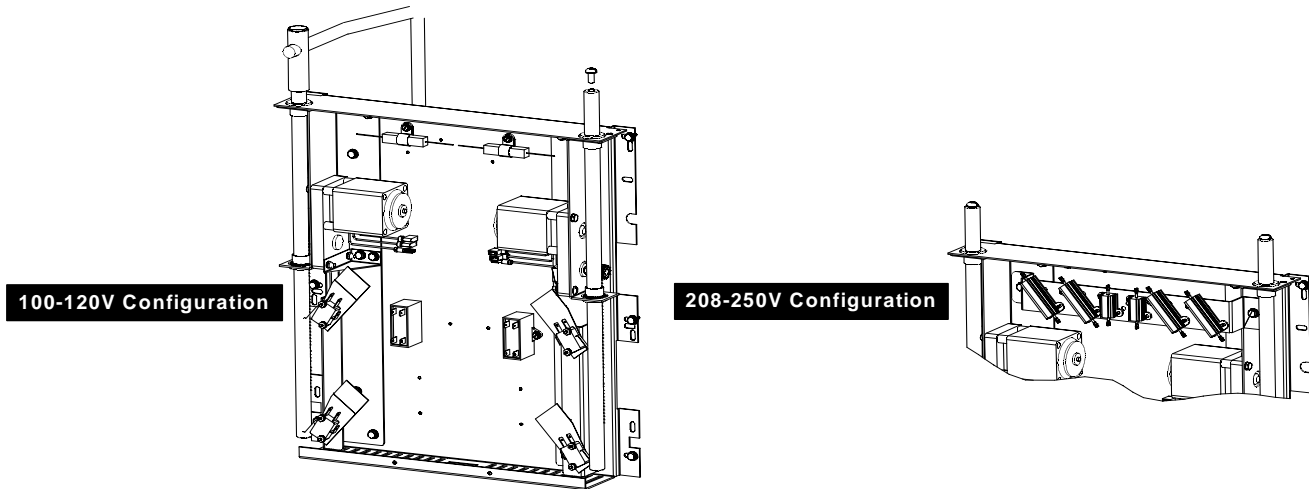

Binding and Jamming Issues

Noisy, jerky or erratic movement of the lifts is usually due to lack of lubrication of the rods and their bushings. Apply a light coat of Lubriplate[®] or similar lightweight white grease to the rod and bushings to correct the problem.

With the modular basket lift, another possible cause of binding is improper positioning of the motor, which prevents the gear from correctly engaging the teeth in the rod. To correct the problem, loosen the screws that hold the motor in place and move it forward or backward until the rod has just enough slack to be rotated slightly.

Motor and Gear Issues

With the modular basket lift, the most likely problem to be encountered in this category is erratic motion of the lift due to a worn drive gear. Failure to keep the lift rod and bushings properly lubricated will cause unnecessary wear of the gear. The problem is corrected by replacing the worn gear.

If the lift cycles correctly but fails to remain in the up position (i.e., goes up, but then slowly settles back down into the frypot), the problem is a failed motor brake. A failed motor brake cannot be repaired and requires replacement of the motor itself.

If power is reaching the motor but the motor fails to run, the motor is burned out and must be replaced.

Electronic Issues

Within this category are problems associated with the relays, microswitches, capacitors, resistors, interface board, wiring, and controls. The most common problem in this category is a lift that continuously travels up and down. This is usually caused by a microswitch that is out of adjustment. Troubleshooting the electronics of a modular basket lift is simply a process of verifying current flow through the individual components up to and including the motor. Using a multimeter set to the 250 VAC range, check the connections on both sides of the component for the presence of the applied line voltage. The schematic below and the wiring diagram on page 1-27 and 1-28 can identify the components and wiring connection points.

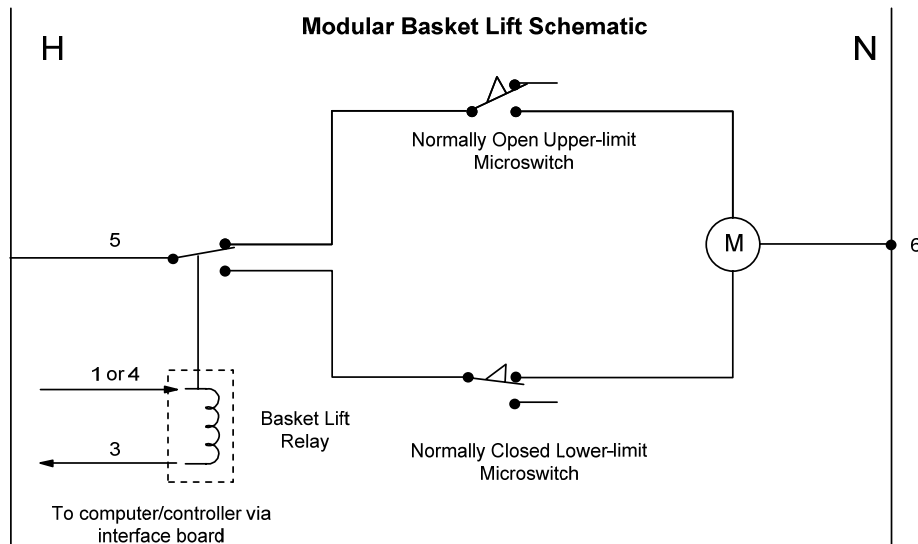

1.11 ATO (Automatic Top-off) Service Procedures

The automatic top-off system is activated when the oil level falls below a sensor in the rear of the frypot. The signal is sent to the ATO board to engage the solenoid to the frypot and turn on the ATO pump. The pump draws oil from the JIB (Jug In Box) to a port in the rear of the frypot. Once the oil level has satisfied the sensor, the pump and solenoid turn off.

The ATO board is located inside the box, behind the JIB (see Figure 1). The power for the ATO board is supplied from the right hand component box. The power passes through the transformer inside the ATO box to the board.

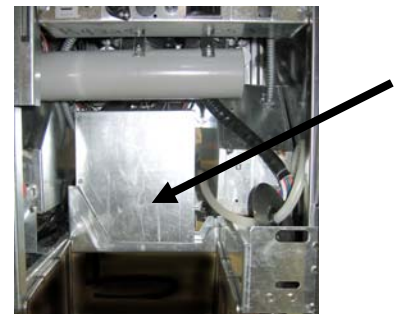

Figure 1

1.11.1 ATO (Automatic Top-off) Troubleshooting

Problem	Probable Causes	Corrective Action
Frypots won't top off.	<ul style="list-style-type: none"> A. JIB out of oil B. Supply line from JIB is clogged. C. Probe temperature lower than setpoint. D. Temperature in supply line or JIB is too low. E. ATO board power loss F. Failed solenoid. G. ATO pump failed or over tightened. H. Failed transformer/harness. I. Failed ATO board. 	<ul style="list-style-type: none"> A. Ensure the JIB is not out of oil and supply line is in the JIB. Replace JIB and press the ▲ button when prompted to reset top off system. B. Remove supply line from pump and blow air through line towards JIB. C. Check to see that fryer is heating. Fryer temperature must be at least 300°F (149°C). Check probe resistance. If probe is bad, replace the probe. D. Ensure oil is above 70°F (21°C). E. Power to the ATO board has been cut off. Restore power to the board and switch all controllers off and on again to readdress system. F. Check solenoid to see if functioning properly. G. If the solenoid is working, ensure that the screws on the bottom of the pump are not too tight. Loosen the screws. If loosening the screws doesn't fix the problem, replace the pump. H. Ensure transformer in ATO box is functioning properly. Check power from transformer to ATO board. Ensure all harnesses are plugged securely into place. I. Check for proper voltages using the pin position chart found on page 1-17. If ATO found defective, replace ATO board.
Controller displays TOPOFF OIL EMPTY / CONFIRM	Top off system out of oil.	Fill top off system with oil and press the ▲ (CONFIRM) button.
Frypot tops off cold.	Incorrect setpoint	Ensure setpoint is correct.
No power to ATO board	<ul style="list-style-type: none"> A. J5 connection unplugged B. Fuse blown C. Transformer malfunction 	<ul style="list-style-type: none"> A. Check to ensure J5 on front of ATO board is fully locked into connector. B. Ensure fuse below right control box is not blown and fuse on the right side of ATO box is not blown. C. Check that proper voltage is present at transformer.
One vat doesn't top off.	<ul style="list-style-type: none"> A. Filter error exists. B. Pump, loose connection, RTD or ATO issue. 	<ul style="list-style-type: none"> A. Clear filter error properly. B. Check ATO pump, wire connections, RTD and ATO board.
One vat tops off but other vats fail to top off.	<ul style="list-style-type: none"> A. Failed solenoid B. Loose wire connection. 	<ul style="list-style-type: none"> A. Check power to the pump. If the pump is hot, the solenoid has probably failed. B. Ensure all wiring harnesses are securely connected to ATO board and solenoids.

Problem	Probable Causes	Corrective Action
Incorrect vat tops off.	<ul style="list-style-type: none"> A. Wired incorrectly. B. Flexlines connected to wrong vat. 	<ul style="list-style-type: none"> A. Ensure wires are wired correctly. B. Switch flexlines to correct vat.
3000 displays SERVICE REQUIRED – ATO BOARD	<ul style="list-style-type: none"> A. Loose or bad fuse B. Bad Connection C. ATO Board power loss 	<ul style="list-style-type: none"> A. Ensure fuse on right side of ATO box is secure and good. If the controller above the ATO box is missing power check the fuse below the component box. B. With the controller OFF, press TEMP button and ensure the ATO software version appears. If not, the connection between the ATO and the controller may be bad. Ensure the 6-pin CAN connectors are tight between controller (J6 and J7) and ATO (J9 or J10) boards. C. Power to the ATO board has been cut off. Ensure there is correct voltage to the ATO transformer. Restore power to the board and clear any service required errors.

1.11.2 Testing ATO RTD probes.

The controller features a quick way to compare the temperature of the ATO RTD to the vat temperature. This is useful for diagnosing ATO issues.

With the controller OFF, press and hold the TEMP button. The controller will display AIF and ---- followed by ATO and current resistance temperature. Ignore the AIF display. Compare the resistance of the ATO probe against the controller reading. If the values differ greatly a harness issue may exist.

1.11.3 ATO (Automatic Top-Off) Board Pin Positions and Harnesses

Connector	From/To	Harness #	Pin #	Function	Voltage	Wire Color
J8	Solenoids	8075161	1	Output DV - Vat #1	Ground	Green
			2	Output FV - Vat #1		Red
		8075162- (4 or 5 battery)	3	Output DV - Vat #2		Green
			4	Output FV - Vat #2		Red
			5	Output DV - Vat #3		Green
			6	Output FV - Vat #3		Red
	Top Off Pump Relay		7	Top Off Pump	24VAC	Red
	JIB Reset Switch		8	JIB Reset	16VDC	Red
	Solenoids	8075161 8075162- (4 or 5 battery)	9	24VAC DV - Vat #1	24VAC	White
			10	24VAC FV - Vat #1		Black
			11	24VAC DV - Vat #2		White
			12	24VAC FV - Vat #2		Black
			13	24VAC DV - Vat #3		White
			14	24VAC FV - Vat #3		Black
	Top Off Pump Relay		15	Ground	24VAC	Black
	JIB Reset Switch		16	Ground	16VDC	Black
J4 (Rear) / J5 (Front)	Transformer	8074553	1	24VAC Ret	24VAC	Orange
			2	24VAC		Blue
			3			
			4			
			5	12VAC Ret	12VAC	Red
			6	12VAC		Brown
			7			
			8			
J3 - Vat 5&6 J2 - Vat 3&4 J1 - Vat 1&2	ATO RTD	1080501 (FV) 1080502 (DV)	1	DV - Probe Ground	Ohm	White
			2	DV - Probe		Red
			3	FV - Probe Ground		White
			4	FV - Probe		Red
J6			1			
			2			
J10	Network Resistor (pins 2 & 3) or to next ATO Board (4 & 5 vat units)	8074552	1	Ground		Black
			2	CAN Lo		Red
			3	CAN Hi		White
			4	5VDC+	5VDC	Black
			5	24VDC	24VDC	Red
			6	Ground		White
J9	3000 J7	8074646	1	Ground		Black
			2	CAN Lo		Red
			3	CAN Hi		White
			4	5VDC+	5VDC	Black
			5	24VDC	24VDC	Red
			6	Ground		White

1.11.4 Replacing the ATO Board, ATO Pump Relay or Transformer

Disconnect the fryer from the electrical power supply. Locate the ATO box (see Figure 1 on page 14), behind the JIB (Jug In Box). Remove the cover to expose the transformer and ATO board (see Figure 2). Mark and unplug any wires or harnesses. Replace the defective component and reattach all wires or harnesses. Replace the cover. Once replaced, reconnect the power.

CYCLE POWER TO ENTIRE FRYER SYSTEM. See section 1.11.7 on page 1-19 to reset control power. Check software version and if necessary update the software. If a software update is necessary, follow the

instructions to update the software in section 1.13. Remove and restore power to ALL controllers after power has been restored to the ATO board. Press the TEMP button on one of the M3000 controllers, with the controller in the OFF position, to verify software version of the ATO. If the version is not visible, the ATO may not be connected properly.

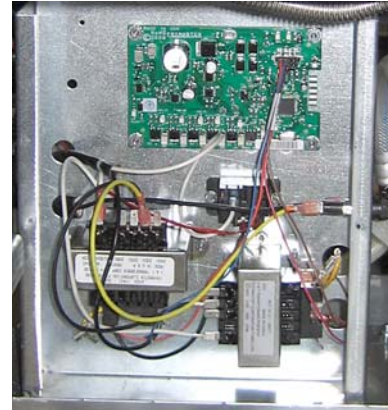

Figure 2

1.11.5 Replacing the ATO Pump

Disconnect the fryer from the electrical power supply. Locate the ATO pump (see Figure 3), behind the ATO box. Mark and unplug any wires or harnesses. Press up from the bottom on the quick disconnects to release the plumbing (see Figure 4). The plumbing can be pulled from the pump. Loosen the four nuts attaching the pump to the pump tray. Replace the defective component and reverse above steps. Once replaced, reconnect the power.



Figure 3



Figure 4

1.11.6 Replacing the ATO Solenoids

Disconnect the fryer from the electrical power supply. Locate the top off manifold in the rear of the fryer. The top off manifold is the smaller of the two manifolds. The solenoids are attached to the manifold (see Figure 5). Mark and unplug any wires. Replace the defective component and reattach all wires or harnesses. Once replaced, reconnect the power.



Solenoid

Figure 5

1.11.7 Control Power Reset Switch

The control power reset switch is a momentary rocker switch located behind the control box, (see Figures 6 and 7) above the JIB, which resets all power to all the controllers and boards in the fryer. It is necessary to reset all power after replacing any controller or board. Press and hold the switch for at least ten seconds when resetting the control power to ensure power has sufficiently drained from boards.



Figure 6

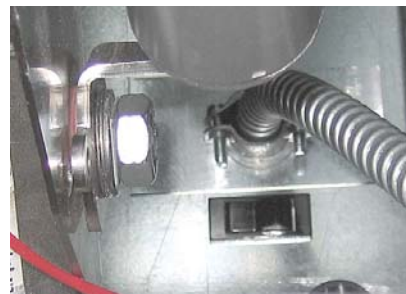

Figure 7 (Rear view of Control Box)

1.12 3000 Controller Service Procedures

1.12.1 3000 Controller Troubleshooting

Problem	Probable Causes	Corrective Action
<p>No Display on Controller.</p>	<ul style="list-style-type: none"> A. Controller not turned on. B. No power to the fryer. C. Power switch turned off. D. Loose fuse holder. E. Controller has failed. F. Damaged controller wiring harness. G. Power supply component or interface board has failed. 	<ul style="list-style-type: none"> A. Press the ON/OFF switch to turn the controller on. B. Verify controller power cord is plugged in and that circuit breaker is not tripped. C. Some fryers have a rocker power switch inside the cabinet below the controller. Ensure the switch is turned on. D. Ensure fuse holder is screwed in properly. E. Swap the controller with a controller known to be good. If controller functions, replace the controller. F. Swap with a harness known to be good. If controller functions, replace the harness. G. If any component in the power supply system (including the transformer and interface board) fail, power will not be supplied to the controller and it will not function.
<p>3000 display shows FILTER BUSY.</p>	<ul style="list-style-type: none"> A. Another filtration cycle is still in process. 	<ul style="list-style-type: none"> A. Wait until the previous filtration cycle ends to start another filtration cycle. This may take up to one minute. If filter busy is still displayed with no activity, remove and restore ALL power to the fryer.
<p>3000 display shows RECOVERY FAULT.</p>	<p>Recovery time exceeded maximum time limit for two or more cycles.</p>	<p>Silence the alarm by pressing the ▲ button. Check that fryer is heating properly. Maximum recovery for an electric fryer is 1:40.</p>

Problem	Probable Causes	Corrective Action
<p>3000 display is in wrong temperature scale (Fahrenheit or Celsius).</p>	<p>Incorrect display option programmed.</p>	<p>Fryers using the 3000 controller can toggle between F° to C° by pressing the ✓ button until Main Menu changing to Product setup is displayed. Press ► to scroll to Tech Mode and press ✓. Enter 1658. Press the scan button. The controller displays OFF. Turn the controller on to check temperature. If the desired scale is not displayed, repeat. Fryers using the CM3.5 should refer to the separate Fryer Controllers User's Manual.</p>
<p>3000 displays SERVICE REQUIRED followed by the error .</p>	<p>An error has occurred.</p>	<p>Press YES to silence alarm. The error is displayed three times. See list of issues in section 1.12.4. Fix issue. The controller displays SYSTEM ERROR FIXED? YES/NO. Press YES. Pressing NO will allow the fryer to cook but the error will be redisplayed every 15 minutes.</p>
<p>Controller displays CHANGE FILTER PAPER?</p>	<p>Daily filter paper change prompt has occurred.</p>	<p>Press ▲ (YES), follow prompts and change the filter paper.</p>
<p>3000 display shows HOT-HI-1.</p>	<p>Frypot temperature is more than 410°F (210°C) or, in CE countries, 395°F (202°C).</p>	<p>This is an indication of a malfunction in the temperature control circuitry, including a failure of the high-limit thermostat.</p>
<p>3000 display shows HI-LIMIT.</p>	<p>Controller in high-limit test mode.</p>	<p>This is displayed only during a test of the high-limit circuit and indicates that the high-limit has opened properly.</p>
<p>3000 display shows temperature alternating with MLT-CYCL.</p>	<p>Frypot temperature is below 180°F (82°C).</p>	<p>This display is normal when the fryer is first turned on while in the melt cycle mode. To bypass the melt cycle press and hold the EXIT COOL button for three seconds. EXIT MELT alternating with YES/NO is displayed. Press the YES button.</p>
<p>3000 display shows LOW TEMP alternating with temperature.</p>	<p>Frypot temperature is between 180°F (82°C) and 315°F (157°C).</p>	<p>This display is normal when the fryer is heating and out of melt cycle until the temperature reaches ±2° of setpoint.</p>
<p>Controller displays LO or LOW TEMP.</p>	<p>Frypot temperature has dropped more than 21°F (12°C) for CM3.5 or 40°F (17°C) for 3000 controllers below setpoint in idle mode or 45°F (25°C) in cook mode.</p>	<p>This display is normal for a short while if a large batch of frozen product is added to the frypot or if the fryer is not heating properly.</p>
<p>3000 display shows LOW TEMP, heating indicator cycles on and off normally but fryer does not heat.</p>	<p>A. Failed controller. B. Damaged controller wiring harness.</p>	<p>A. Replace controller. B. Replace controller wiring harness.</p>

Problem	Probable Causes	Corrective Action
3000 display shows TEMP PROBE FAILURE.	Problem with the temperature measuring circuitry including the probe.	This indicates a problem within the temperature probe circuitry. Check resistance of probe, if faulty replace probe.
3000 display shows PROBE FAILURE with alarm sounding.	Damaged controller wiring harness or connector.	Swap the controller wiring harness with one known to be good. If problem is corrected replace harness.
Controller will not go into program mode or some buttons do not actuate.	Failed controller.	Replace controller
3000 display shows HI 2 BAD.	Controller in high-limit test mode.	This is displayed only during a test of the high-limit circuit and indicates that the high-limit has failed.
3000 display shows HEATING FAILURE with alarm sounding. Heating indicator is on, but fryer is not heating.	Failed controller, failed interface board or open high limit thermostat.	Check high limit thermostat, interface board and controller.
3000 display shows HEATING FAILURE and alarm sounds, but fryer operates normally (false alarm).	Failed controller.	Replace controller.
3000 display shows CLOSE DRAIN VALVE.	Drain valve is open or switch is out of adjustment or failed.	Ensure all drain valves are completely closed and that microswitches are adjusted and working.
3000 display shows software for only 3000 or ATO board.	Loose or damaged harness	Check that all harnesses between 3000's and ATO are secure and no pins are pushed out or broken.
3000 display shows ERROR RM SDCRD	Defective SD Card	Replace card with another card.
3000 display shows CALL TECH	Typically shown during software update. Also may be that parameter data has been corrupted or lost.	Press the FILTER button to bypass and continue.

1.12.2 3000 Controller Useful Codes

To enter any of the following codes: Press and hold the ✓ button until **MAIN MENU** changing to **PRODUCT SETUP** is displayed. Press ► to scroll to **TECH MODE** and press ✓. **TECH MODE ENTER CODE** is displayed. Enter a code number below:

- **Change Fryer Type, CE/Non-CE, Fresh Oil Setup, Waste Oil Setup and Energy Type – Enter 1628.**
- **Clear E-Log, Clear Passwords, Change Lane Count, Adjust Max Cook Temp and Perform High Limit Test, – Enter 3000.**
- **Reset Factory Menu - Enter 3322.** The controller display flashes and quickly counts from 1-40 and switches to **OFF**. (**NOTE:** This will delete any hand-entered menu items).
- **Reset BADCRC Message -** Disconnect board locator plug (J3). Reinsert plug. Enter **9988**. Controller display switches to **OFF**. Remove and then restore power to the controller using the 20-pin plug.
- **Change from F° to C° - Enter 1658.** The controller displays **OFF**. Turn the controller on and check temperature to see the temperature scale. If the desired scale is not displayed, repeat.
- **Reset RECOVERY FAULT CALL SERVICE – Enter 0042.**

PASSWORDS

Product Setup Mode: Press and hold the ✓ button until **MAIN MENU** changing to **PRODUCT SETUP** is displayed. Press the ✓ button. **ENTER CODE** is displayed. Enter **1650**.

Vat Setup Mode: Press and hold the ✓ button. **MAIN MENU** changing to **PRODUCT SETUP** is displayed. Press ► to scroll to **VAT SETUP** and press ✓. **ENTER CODE** is displayed. Enter **1656**.

Tech Mode: Press and hold the ✓ button until **MAIN MENU** changing to **PRODUCT SETUP** is displayed. Press ► to scroll to **TECH MODE** and press ✓. **TECH MODE** is displayed. Press the ✓ button. **ENTER CODE** is displayed. Enter **3000** or a code from above.

1.12.3 Service Required Errors

A **SERVICE REQUIRED** error alternating with **YES** displays on the controller. After **YES** is pressed the alarm is silenced. The controller displays an error message from the list below three times with the location of the error. Then the controller displays **SYSTEM ERROR FIXED? YES/NO**. Press **YES** if error is fixed. If **NO** is chosen the system returns to cook mode for 15 minutes then redisplay error until issue is fixed.

1.12.4 Error Log Codes

Code	ERROR MESSAGE	EXPLANATION
E03	ERROR TEMP PROBE FAILURE	TEMP Probe reading out of range
E04	HI 2 BAD	High limit reading is out of range.
E05	HOT HI 1	High limit temperature is past more than 410°F (210°C), or in CE countries, 395°F (202°C)
E06	HEATING FAILURE	A component has failed in the high limit circuit such as controller, interface board, contactor or open-high limit.
E08	ERROR ATO BOARD	ATO board connection lost; ATO board failure
E17	ERROR ATO PROBE	ATO RTD reading out of range
E20	INVALID CODE LOCATION	SD card removed during update
E21	FILTER PAPER PROCEDURE ERROR (Change Filter Paper)	25-hour or customer-set timer has expired.
E22	OIL IN PAN ERROR	Oil may be present in the filter pan.
E25	RECOVERY FAULT	Recovery time exceeded maximum time limit. Recovery time should not exceed 1:40 for electric.
E27	LOW TEMP ALARM	Oil temperature has dropped 30°F (17°C) lower than setpoint in idle mode or 45°F (25°C) in cook mode. (This message may appear if a product is dropped and the start cook button is not pressed immediately or if too large of cook loads are dropped.)

1.12.5 3000 Menu Summary Tree

Reflected below are the major programming sections in the 3000 and the order in which submenu headings will be found under the sections in the 3000 Operation Manual (819-6872).

Adding New Product Menu Items

See section 1.6-1.8

Filter Menu	1.9
[With computer ON, press and hold FILTER button]	
Filter	
Clean and Filter	
Dispose	
Fill Vat From Bulk (Bulk option only)	
Boil Out [With computer OFF, press and hold FILTER button]	
Info Mode	1.5
[Press and hold ✓ (check) button]	
Last Dispose Stats	
Daily Stats	
Selected Period Stats	
Last Load Stats	
Main Menu and Tech Modes	
[With computer OFF, press and hold ✓ (check) button 10 seconds, displays Main Menu - Product Setup]	
Product Setup	1.6-1.8
[Enter 1650]	
Select Product	
Long Name	
Short Name	
Cooking Mode	
1 Time	
1 Tempr	
1 Sensitivity	
1 Alarm Time (Shake)	
1 Alarm Name (Shake)	
1 Alarm Mode (Shake)	
1 Alarm Tone (Shake)	
2 Alarm Time (Shake)	
Filter Prompt	
Instant On	
Hold Time	
Vat Setup	1.4
[Enter 1656]	
System	1.4
Language	
2 nd Language	
Locale (CE or Non-CE)	
Energy (Gas or Elec)	
Type (Vat)	
System Volume (Sound Level)	
Tempr Format (F or C)	
Exit Melt Tempr	
Cool Mode Tempr	
Cool Mode Default	
Fresh Oil	
Waste	
Drain Switch	
Recovery Alarm	
Basket Lift	
Hold Time	
Time/Date	1.4
DST(Daylight Savings Time) Setup.....	1.4
Filter	1.4
Cooks til Filter	
EOD Filter Timer	
EOD Filter Time	
Flushing Timer	
Boil Out Timer	
1 Polish Timer	
1 Polish Prompt Time	
1 Polish Duration	
1 Polish Start Tempr	
List of last 10 error codes	
E-Log	1.4
Change Password	1.4
Tech Mode	
[Enter 3000]	
Clear E-Log	
Clear Passwords	
Lane Count	
Hold Mode	
Max Cook Tempr	
Hi-Limit Test	

1.12.6 3000 Controller Pin Positions and Harnesses

Connector	From/To	Harness PN	Pin #	Function	Voltage	Wire Color		
J2	Interface Board to Controller	8074199 SMT Controller to Interface Board Harness	1	12VAC In	12VAC	Black		
			2	Ground				
			3	12VAC In	12VAC			
			4	FV Heat Demand				
			5	V Relay	12VDC			
			6	DV Heat Demand				
			7	R/H B/L	12VDC			
			8	Analog Ground				
			9	L/H B/L	12VDC			
			10	ALARM				
			11	Sound Device	5VDC			
			12	ALARM				
			13	FV Probe				
			14	Common Probes				
			15	DV Probe				
			16					
			17					
			18					
			19					
			20					
J3	Locator Harness Interface Board Ground to Controller	1080485	1	Vat #1		Black		
		1080486	2	Vat #2				
		1080487	3	Vat #3				
		1080488	4	Vat #4				
		1080489	5	Vat #5				
			6					
J4	Drain Switch	8075159 (FV) 8075160 (DV)	1	FV Drain		Black		
			2	FV Drain		Red		
			3	DV Drain		Black		
			4	DV Drain		Red		
J6	Previous 3000 J7 or Network Resistor	8074546 Controller Communication Harness	1	Ground		Black		
			2	CAN Lo		Red		
			3	CAN Hi		White		
			4					
			5					
			6					
J7	ATO J1 or Next 3000 J6	8074646 Controller Communication Harness	1	Ground		Black		
			2	CAN Lo		Red		
			3	CAN Hi		White		
			4					
			5					
			6					

1.13 Loading and Updating Software Procedures

Updating the software takes approximately 30 minutes. The software only needs to be loaded in **ONE** controller and it will update **all** the controllers and boards in the system. Press the TEMP button to check current 3000/ATO software version. Remove the bezel by removing the screws under the bottom of the bezel. Remove the two screws securing the controller allow it to swing down. Remove the two screws on the left side cover plate of the far left 3000 controller.

To update the software, follow these steps carefully:

Left Display	Right Display	Action
OFF	OFF	With the controller folded down, insert the SD card, with the contacts facing down and the notch on the bottom right (see Figure 8 and 9), into the slot on the left side of the 3000 controller. ENSURE THE CARD IS FULLY INSERTED INTO THE SD CARD SLOT.
UPGRADE IN PROGRESS	WAIT	None required.
CC UPDATING	PERCENTAGE COMPLETE	None required.
UPGRADE IN PROGRESS	WAIT	None required.
CALL	TECH	If this message is displayed, press the FILTER button and the software load will continue.
IF_COOK HEX. IF_ATO HEX	PERCENTAGE COMPLETE	None required.
REMOVE SD CARD	100	Remove the SD card using the fingernail slot on the top of the SD card.
CYCLE POWER.	BLANK	Cycle the control power using the reset switch behind the far right control box. ENSURE THE SWITCH IS HELD FOR 10 SECONDS. WAIT ANOTHER 20 SECONDS AFTER THE RESET BEFORE CONTINUING.
OFF	BOOT	The left controller displays OFF . The remaining controllers display a flashing BOOT while the program is transferred.
LOCALE	NON-CE	Setup the locale, type of fryer, etc. Exit when finished. (Note it may be necessary to enter 7628 in Tech Mode to change fryer type from Legacy to OCF30. Ensure if a JIB is present that Fresh Oil is set for JIB.)
OFF	OFF	Cycle the control power using the hidden reset switch under the left control box again. ENSURE THE SWITCH IS HELD FOR 10 SECONDS WAIT ANOTHER 20 SECONDS AFTER THE RESET BEFORE CONTINUING.
OFF	OFF	With the controller displaying OFF, VERIFY software update by pressing the TEMP button to check updated 3000/ATO version on each controller. IF ANY BOARDS DID NOT UPDATE, REPEAT THE PROCESS BY INSERTING THE SD CARD AGAIN.
OFF	OFF	Once the software has been updated and the versions are correct, replace the cover and screws covering the SD card slot. Replace the screws attaching the controller and replace the bezel and screws.



Figure 8



Figure 9

1.14 Interface Board Diagnostic Chart

The following diagram and charts provide ten quick system checks that can be performed using only a multimeter.

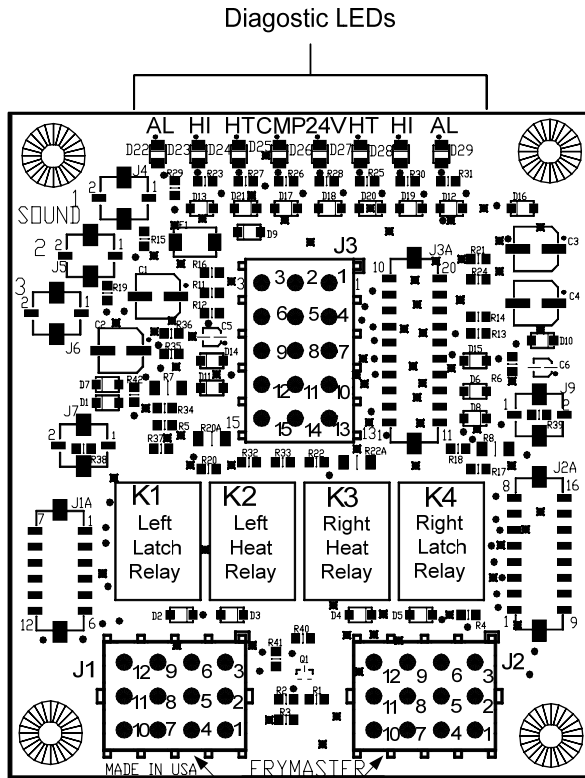

Diagnostic LED Legend	
CMP	indicates power from 12V transformer
24	indicates power from 24V transformer
HI (RH)	indicates output (closed) from right latch relay
HI (LH)	indicates output (closed) from left latch relay
HT (RH)	indicates output from right heat relay
HT (LH)	indicates output from left heat relay
AL (RH)	indicates output (open) from right latch relay
AL (LH)	indicates output (open) from left latch relay

PN 826-2260 (106-6664)

Test Points
J1 Left J2 Right

NOTE – Pin 1 is located in the bottom right corner of Both J1 and J2. These test points are ONLY for the OCF30™ Series boards with J1 and J2 plugs on the front of the board.

Meter Setting	Test	Pin	Pin	Results
12 VAC Power	50 VAC Scale	3 of J2	1 of J2	12-16 VAC
24 VAC Power	50 VAC Scale	2 of J2	Chassis	24-30 VAC
*Probe Resistance (RH)	R X 1000 OHMS	11 of J2	10 of J2	See Chart
*Probe Resistance (LH)	R X 1000 OHMS	1 of J1	2 of J1	See Chart
High-Limit Continuity (RH)	R X 1 OHMS	9 of J2	6 of J2	0 - OHMS
High-Limit Continuity (LH)	R X 1 OHMS	6 of J1	9 of J1	0 - OHMS
Latch Contactor Coil (RH)	R X 1 OHMS	8 of J2	Chassis	3-10 OHMS
Latch Contactor Coil (LH)	R X 1 OHMS	5 of J1	Chassis	3-10 OHMS
Heat Contactor Coil (RH)	R X 1 OHMS	7 of J2	Chassis	11-15 OHMS
Heat Contactor Coil (LH)	R X 1 OHMS	4 of J1	Chassis	11-15 OHMS

* Disconnect 15-Pin harness from the controller/controller before testing the probe circuit.

1.15 Probe Resistance Chart

<h1 style="text-align: center;">Probe Resistance Chart</h1> <p style="text-align: center;"><i>For use with fryers manufactured with Minco Thermistor probes only.</i></p>																	
F	OHMS	C	F	OHMS	C	F	OHMS	C	F	OHMS	C	F	OHMS	C			
60	1059	16	130	1204	54	200	1350	93	270	1493	132	340	1634	171			
65	1070	18	135	1216	57	205	1361	96	275	1503	135	345	1644	174			
70	1080	21	140	1226	60	210	1371	99	280	1514	138	350	1654	177			
75	1091	24	145	1237	63	215	1381	102	285	1524	141	355	1664	179			
80	1101	27	150	1247	66	220	1391	104	290	1534	143	360	1674	182			
85	1112	29	155	1258	68	225	1402	107	295	1544	146	365	1684	185			
90	1122	32	160	1268	71	230	1412	110	300	1554	149	370	1694	188			
95	1133	35	165	1278	74	235	1422	113	305	1564	152	375	1704	191			
100	1143	38	170	1289	77	240	1432	116	310	1574	154	380	1714	193			
105	1154	41	175	1299	79	245	1442	118	315	1584	157	385	1724	196			
110	1164	43	180	1309	82	250	1453	121	320	1594	160	390	1734	199			
115	1174	46	185	1320	85	255	1463	124	325	1604	163	395	1744	202			
120	1185	49	190	1330	88	260	1473	127	330	1614	166	400	1754	204			
125	1195	52	195	1340	91	265	1483	129	335	1624	168	405	1764	207			

1.16 Wiring Diagrams

1.16.1 Modular Basket Lift Wiring Diagram 208-250V

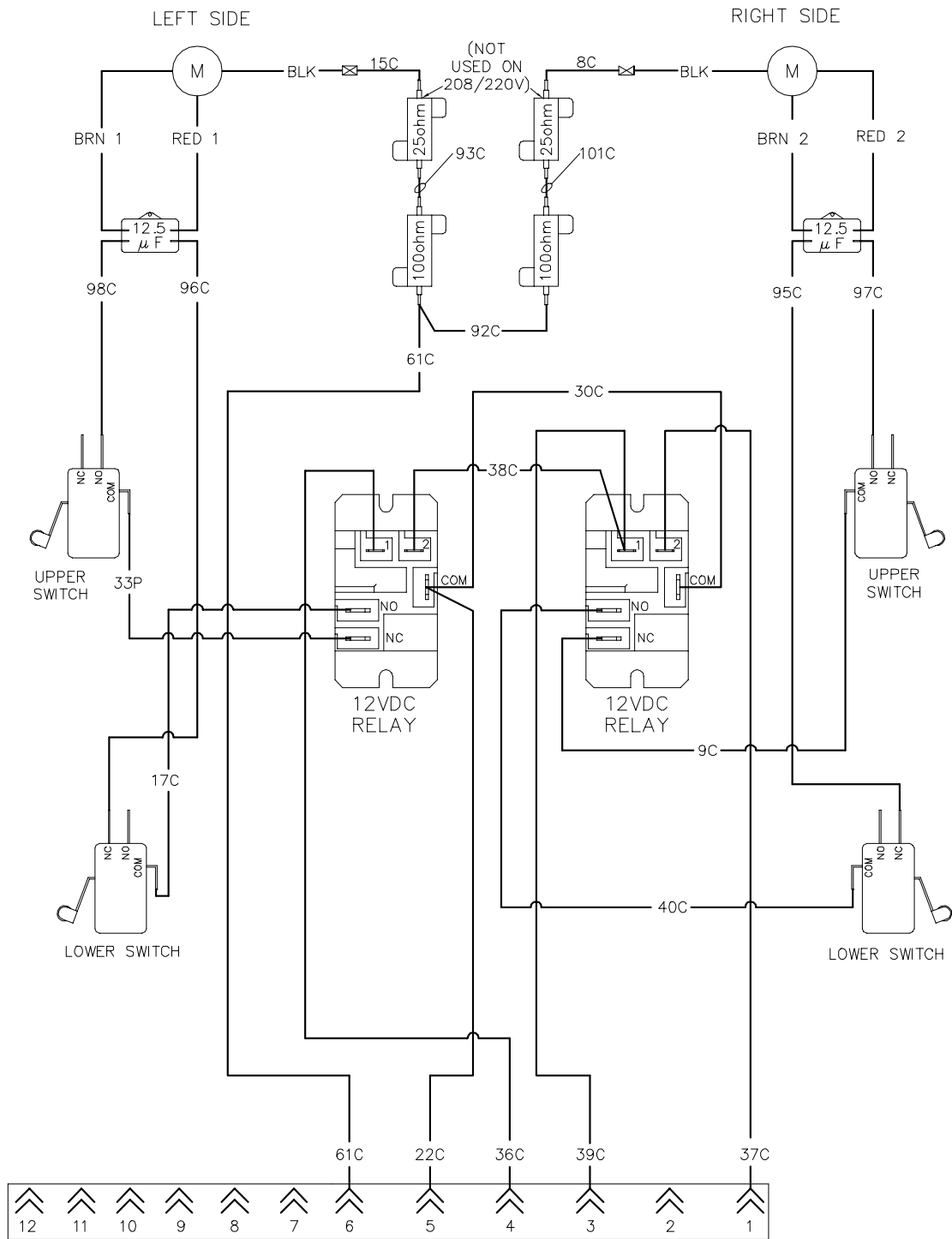

REFERENCES TO LEFT & RIGHT ARE FROM THE REAR OF THE FRYER

8050888D

1.16.2 Modular Basket Lift Wiring Diagram 100-120V

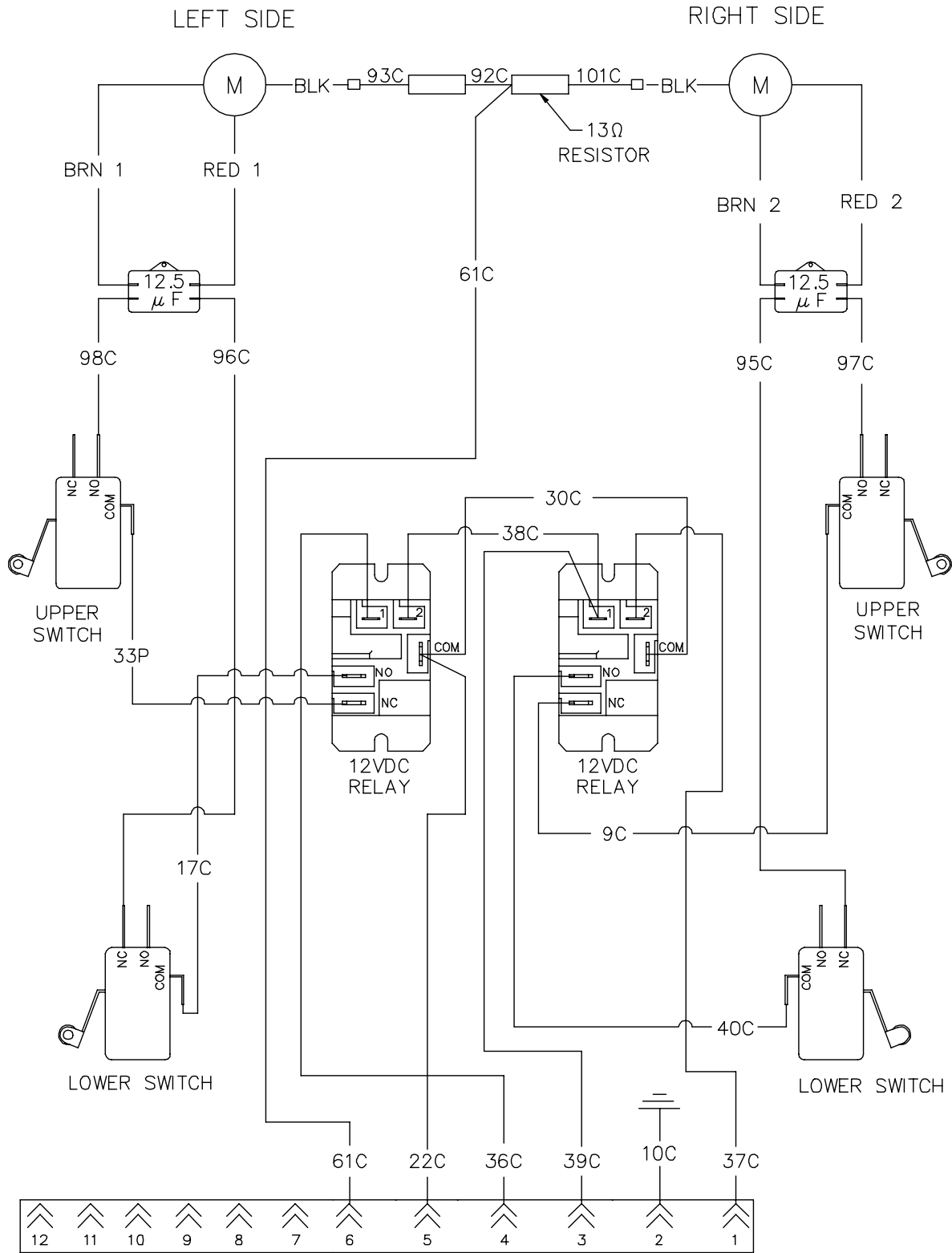

REFERENCES TO LEFT & RIGHT ARE FROM THE REAR OF THE FRYER

8050555E

1.16.3 FPEL Series Simplified Wiring

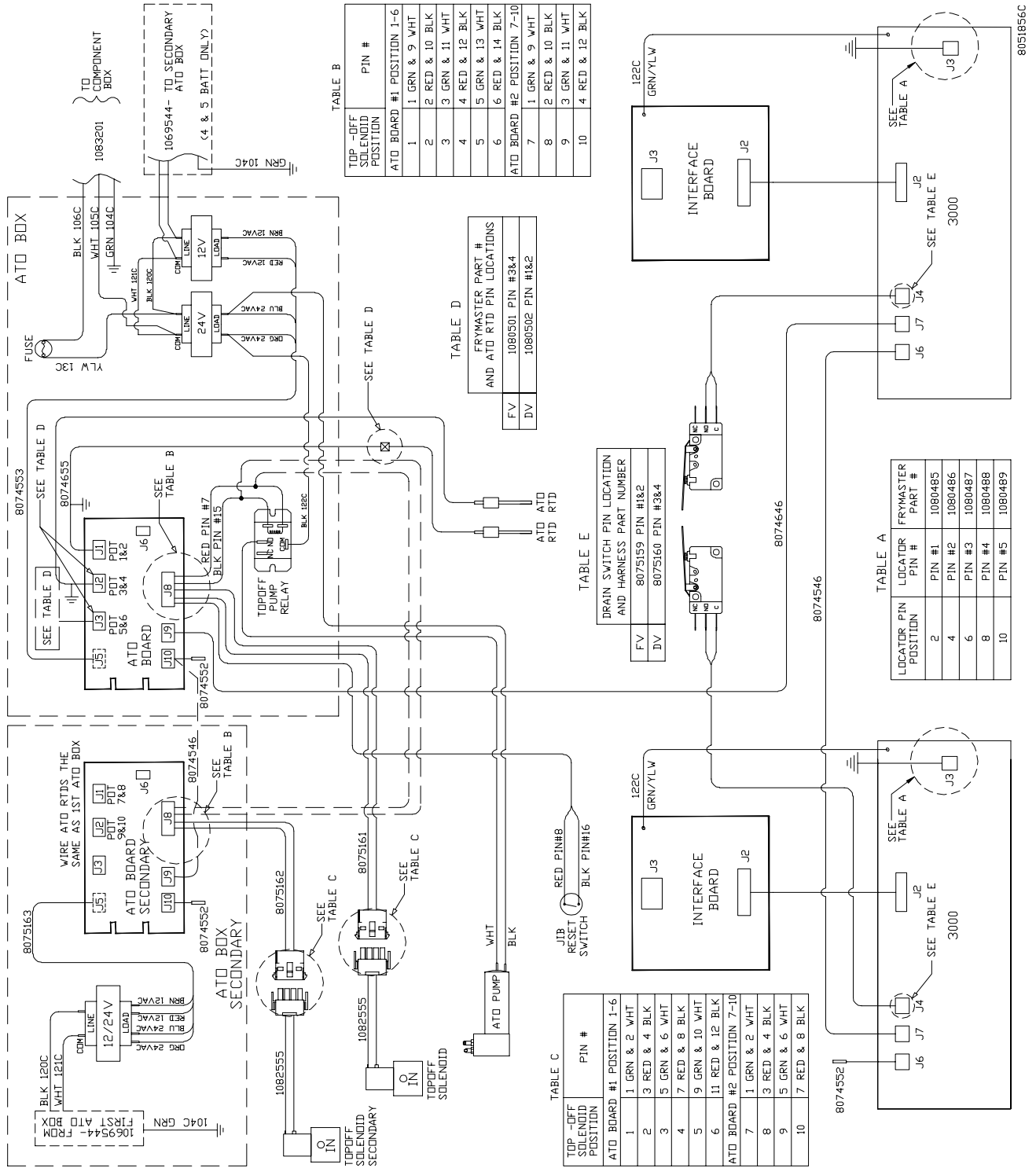

NOTE: If the fryer does not have the optional auto top off feature, an ATO board will not be present. The controllers will terminate on the far left and far right controller.

1.16.4 FPEL Control Wiring (Domestic) with 3000 Controller

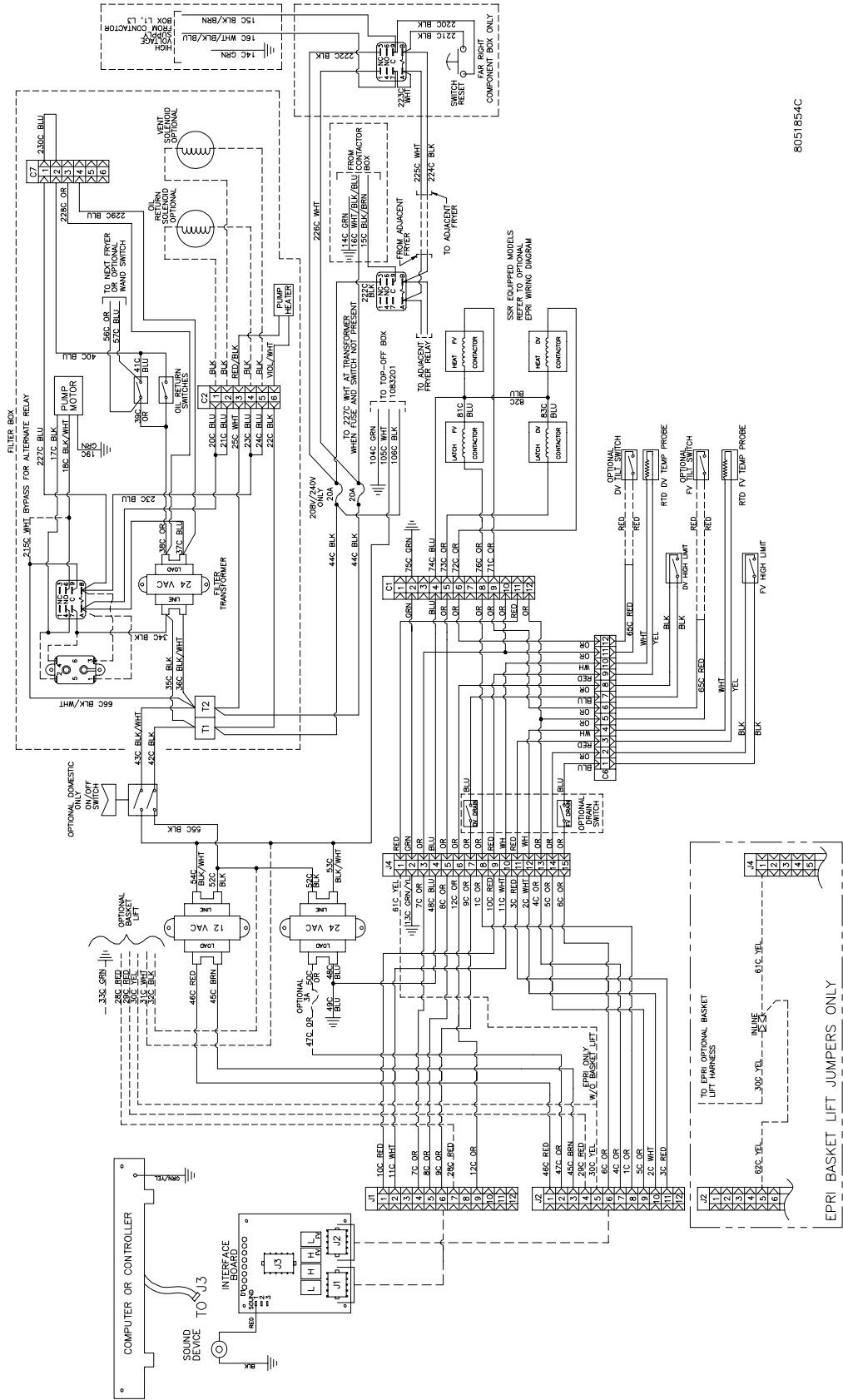

8051854C

1.16.6 Tilt Switch Wiring

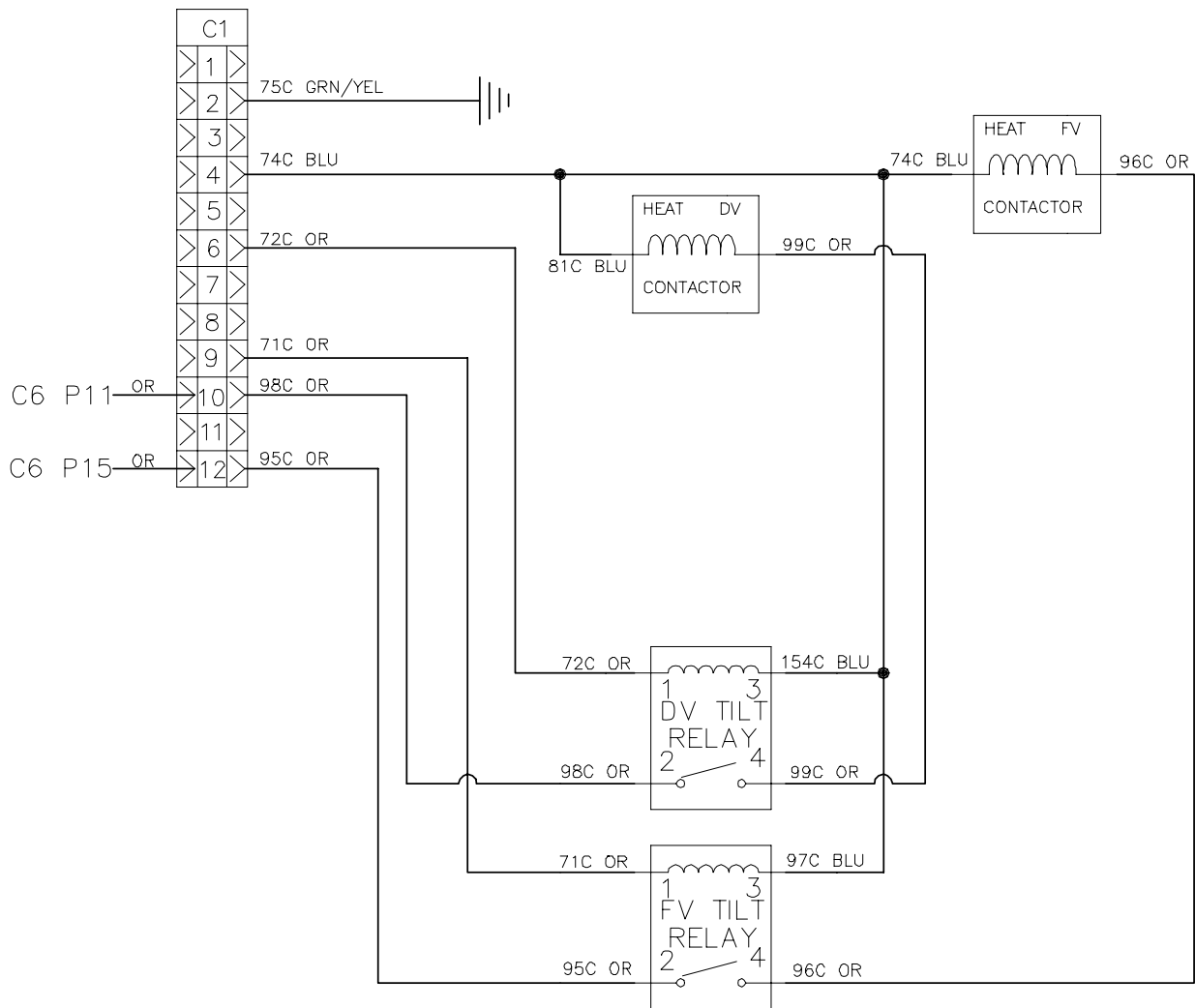

8051612B

1.16.7 Contactor Box – Delta Configuration

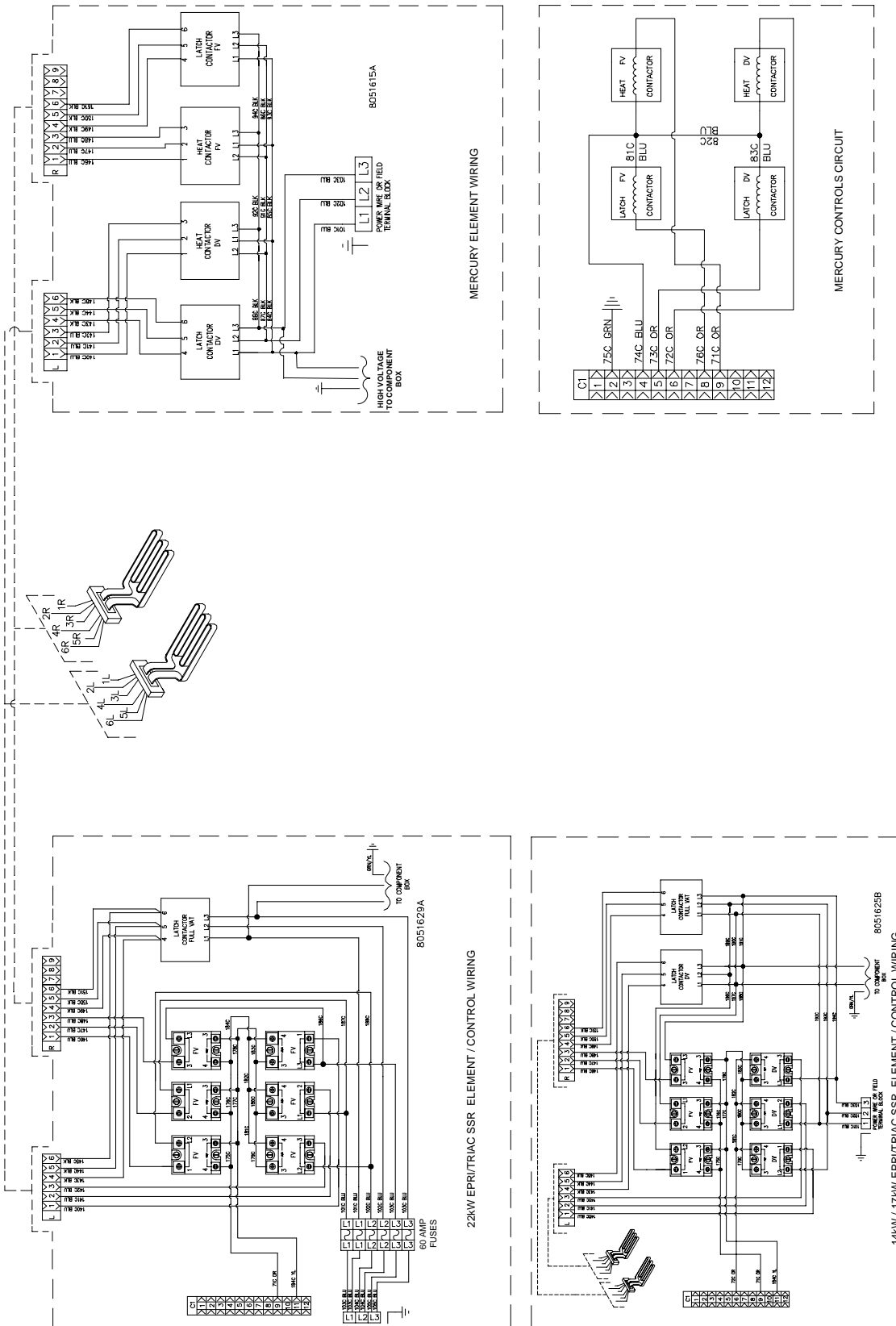

1.16.8 Contactor Box – WYE Configuration

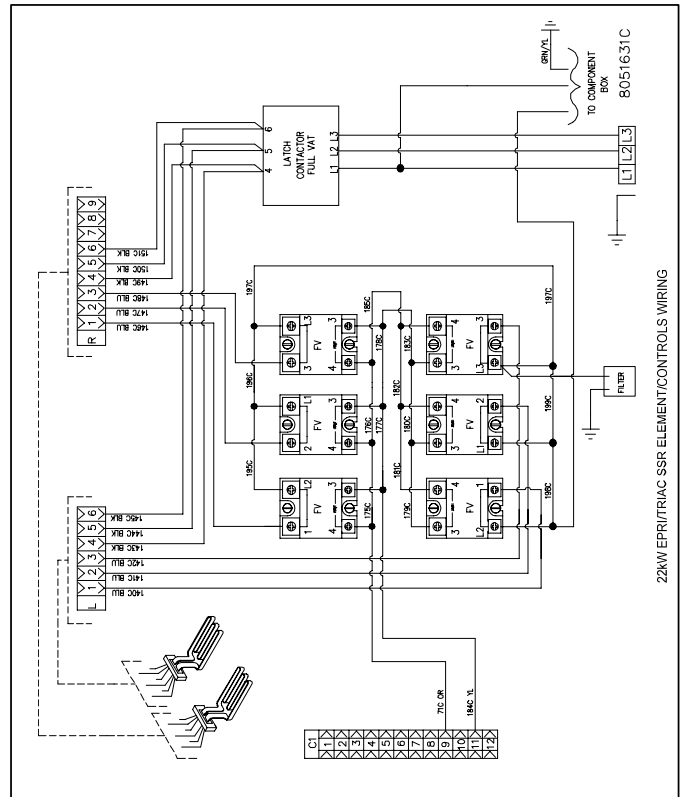
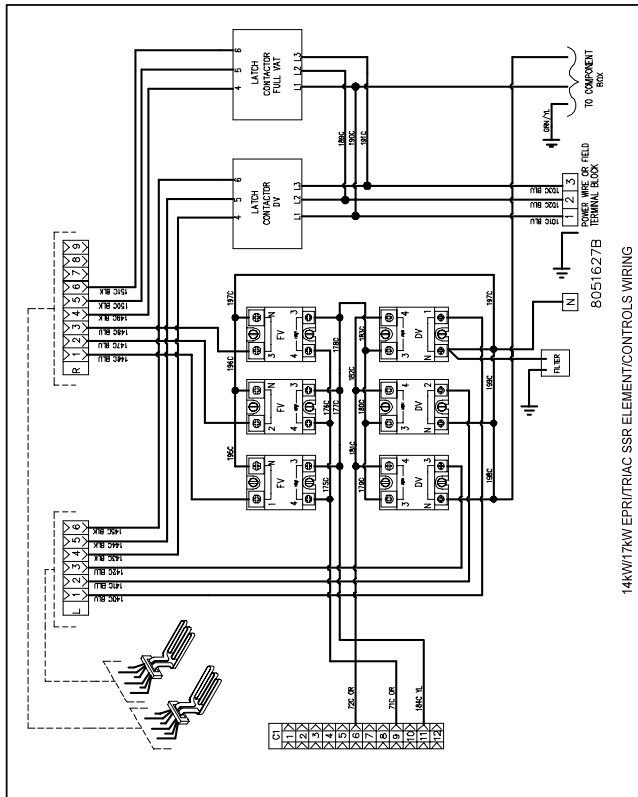
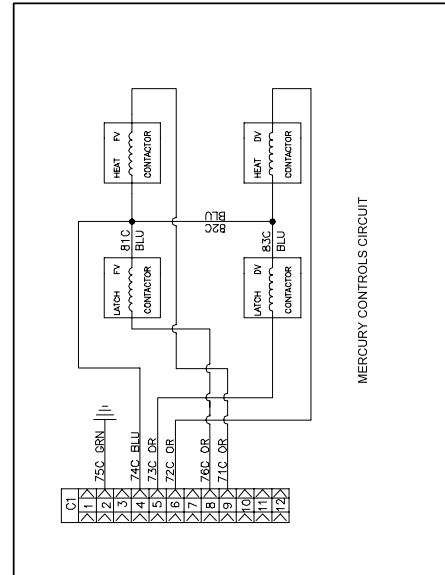
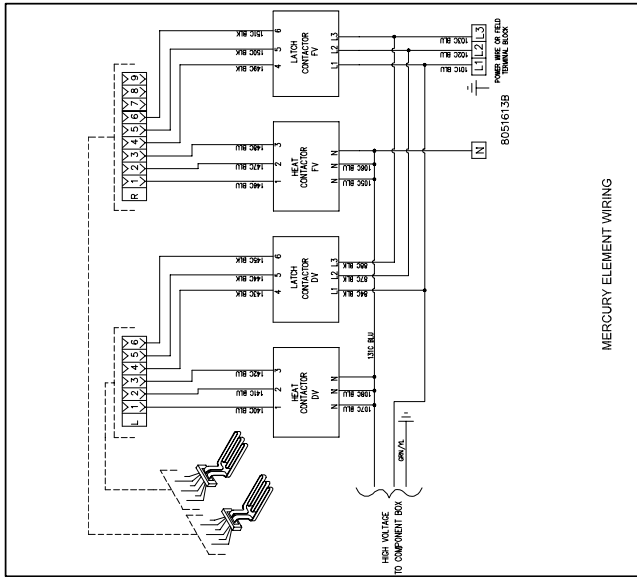

1.16.9 Terminal Block Wiring

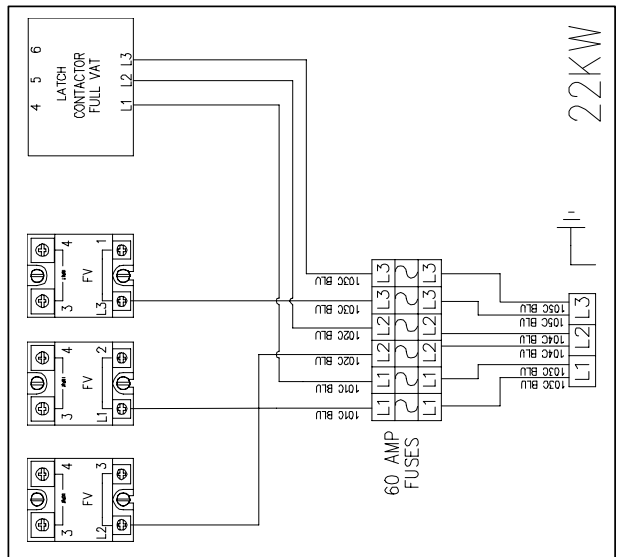
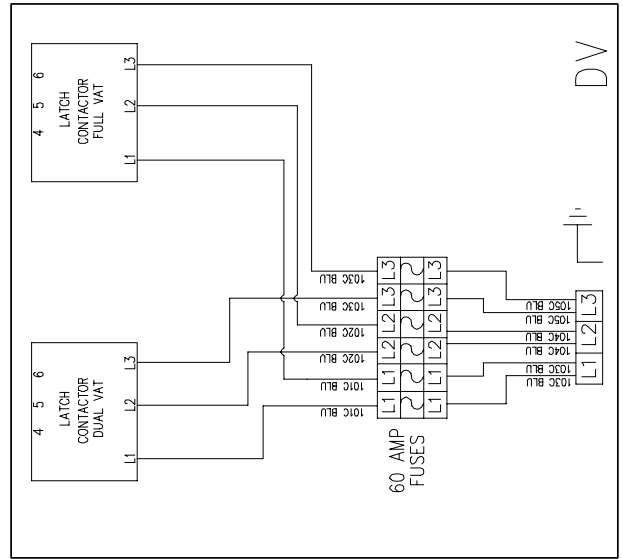
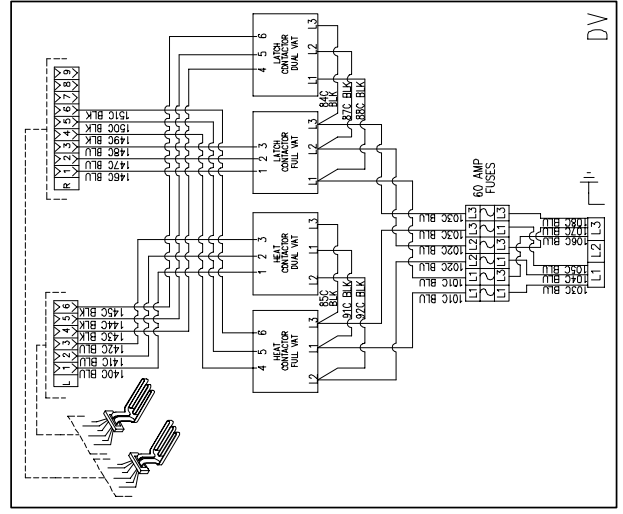
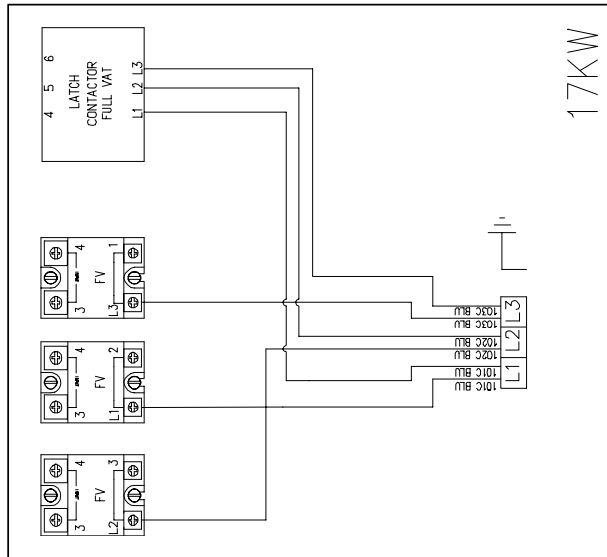
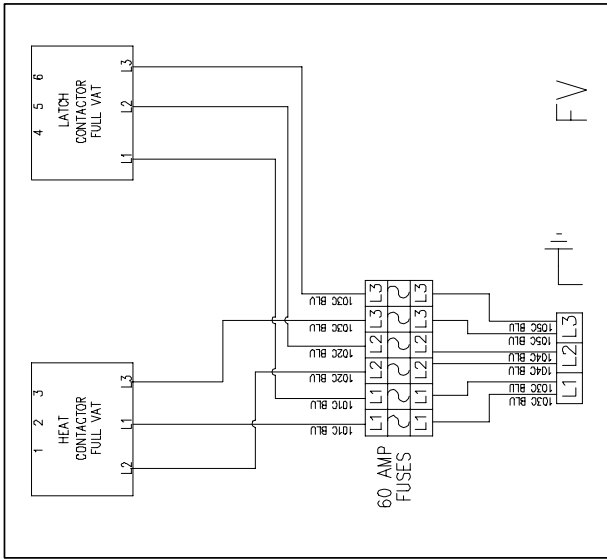
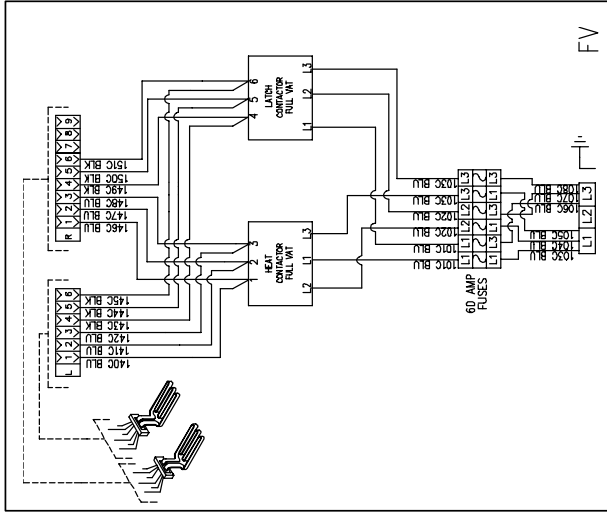

8051652C
SINGLE PHASE TERMINAL BLOCK WIRING DIAGRAMS

8051634B
22kW TERMINAL BLOCK WIRING DIAGRAMS

8051633A
EPR/TRIAC TERMINAL BLOCK WIRING DIAGRAMS

1.16.10 Simplified FPEL14 and 17 Series – Full Vat Delta Wiring

ELECTRIC OCF™ SERIES – FULL-VAT

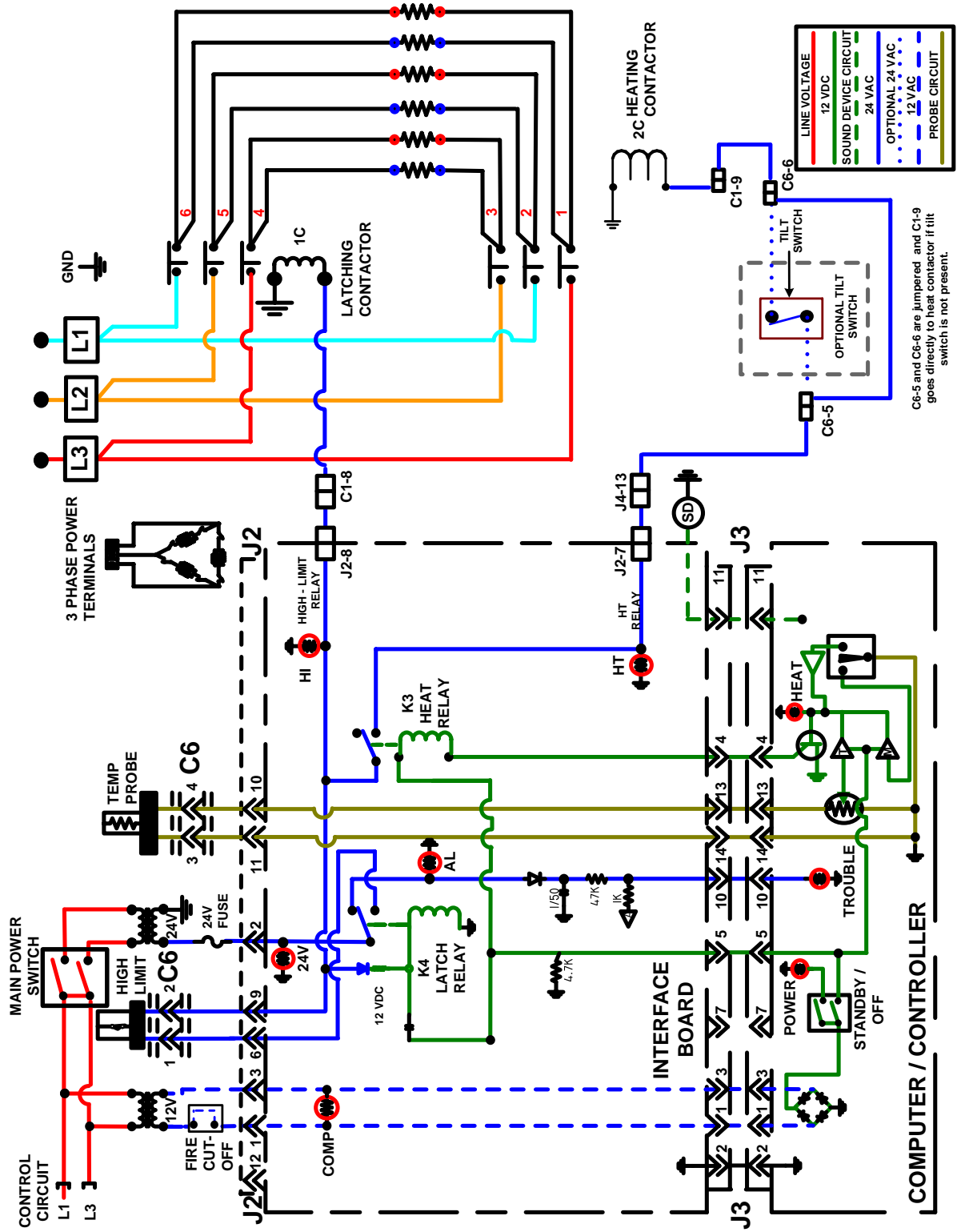

1.16.11 Simplified FPEL14 and 17 Series – Dual Vat Delta Wiring

ELECTRIC OCF™ SERIES - DUAL-VAT

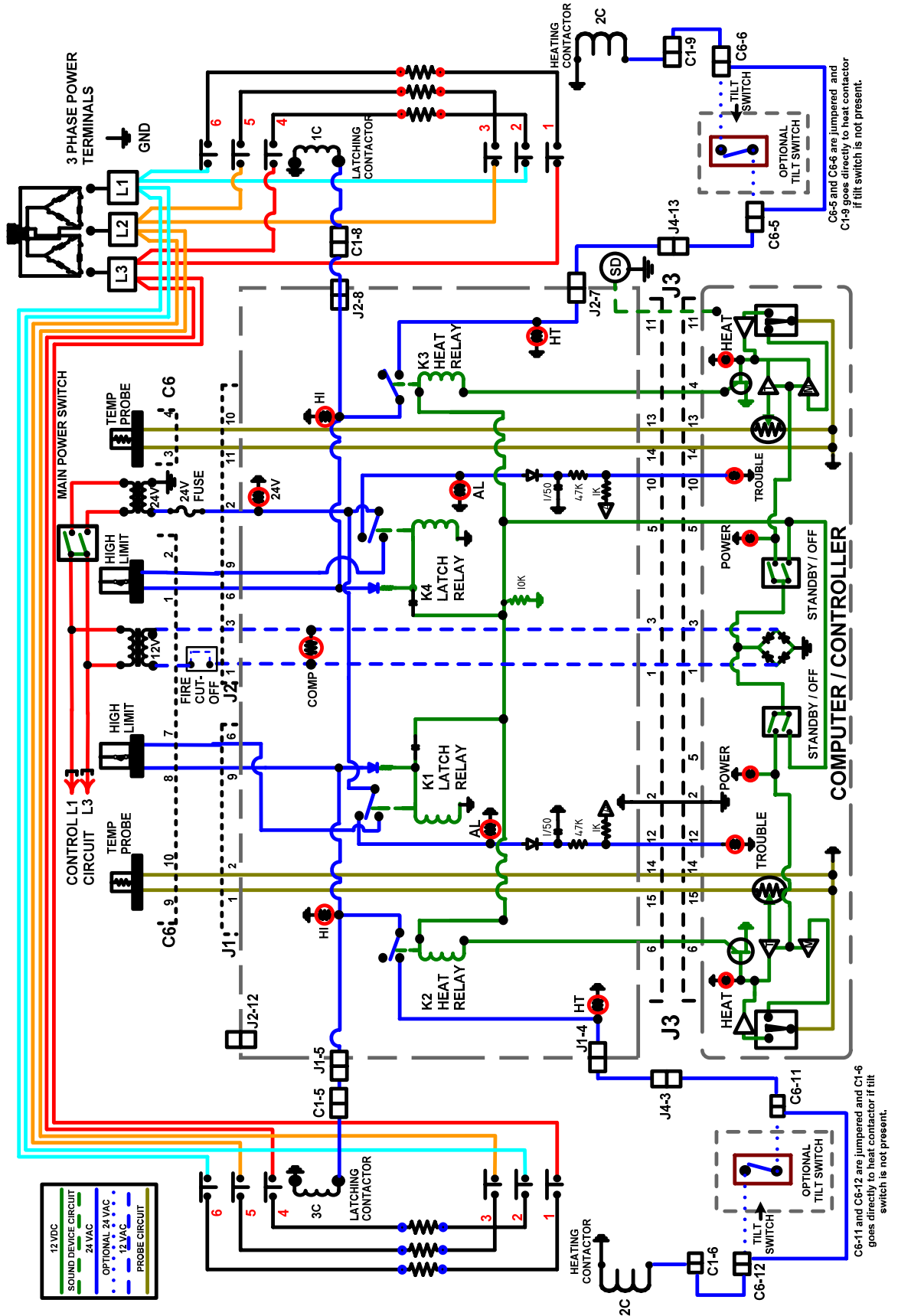

1.16.12 Simplified FPEL14 and 17 Series – Full Vat Wiring EXPORT WYE

ELECTRIC OCF™ SERIES - FULL-VAT EXPORT WYE

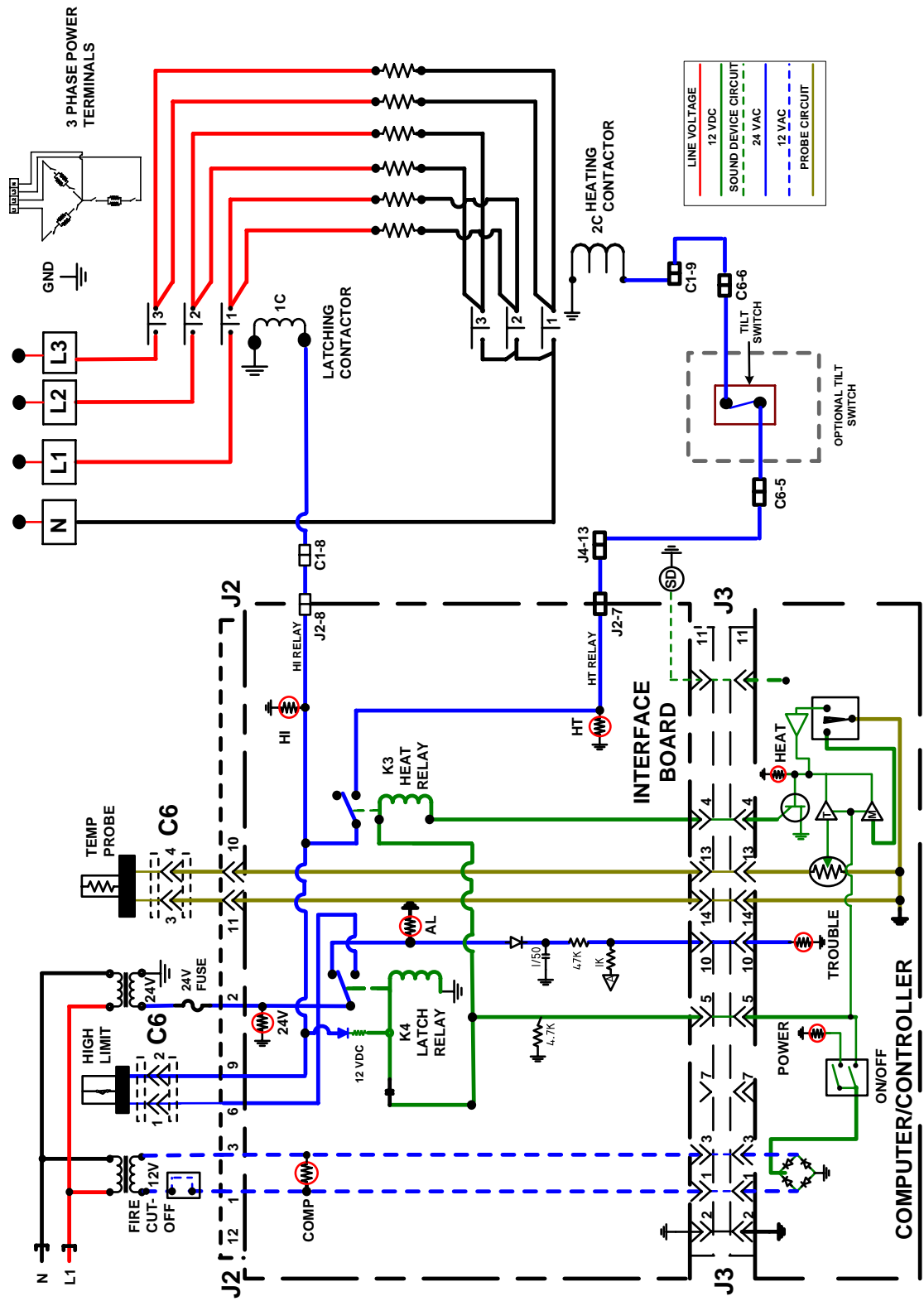

1.16.13 Simplified FPEL14 and 17 Series – Dual Vat Wiring EXPORT WYE

ELECTRIC OCF™ SERIES - DUAL-VAT EXPORT WYE

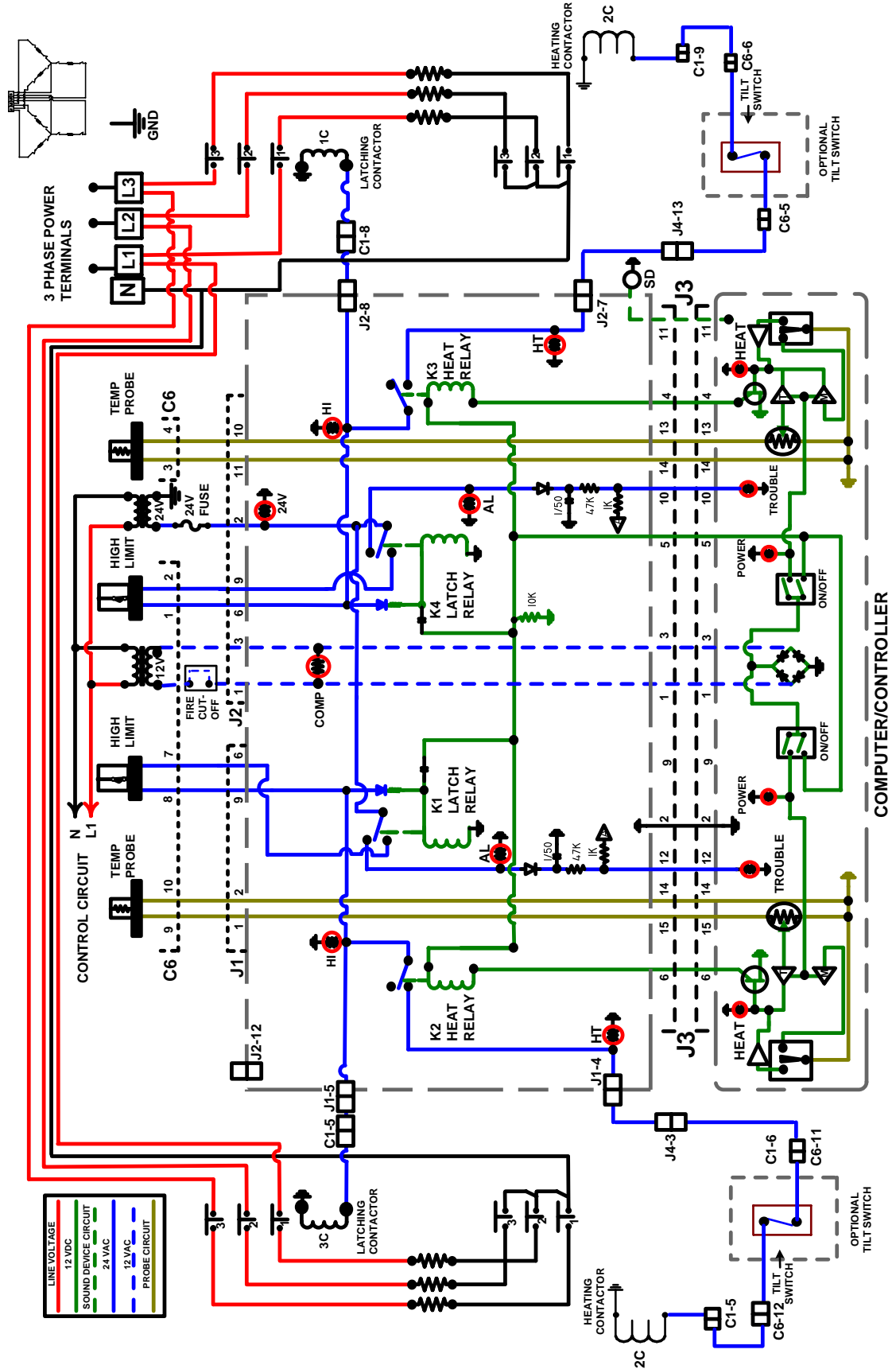

1.16.14 FPEL30 Series Data Network Flowchart

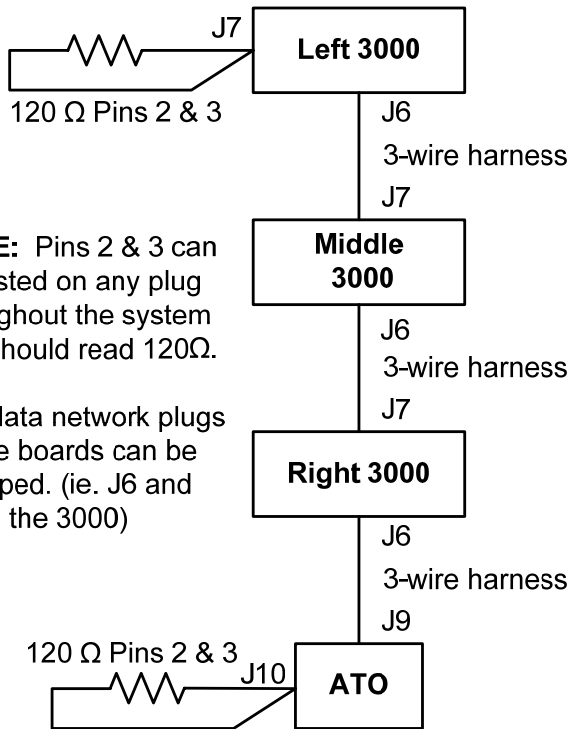

NOTE: Pins 2 & 3 can be tested on any plug throughout the system and should read 120Ω.

The data network plugs on the boards can be swapped. (ie. J6 and J7 on the 3000)

Harness	Pin #	Function	Voltage	Wire Color
3-wire harness	1	Ground		Black
	2	CAN Lo		Red
	3	CAN Hi		White
	4	NOT USED		
	5			
	6			

Turn each computer to OFF. Press the TEMP button on each computer and verify ALL software versions are present (3000 and ATO). A missing version may indicate an open connection.

1.16.15 Shortening Melting Unit Wiring Diagram

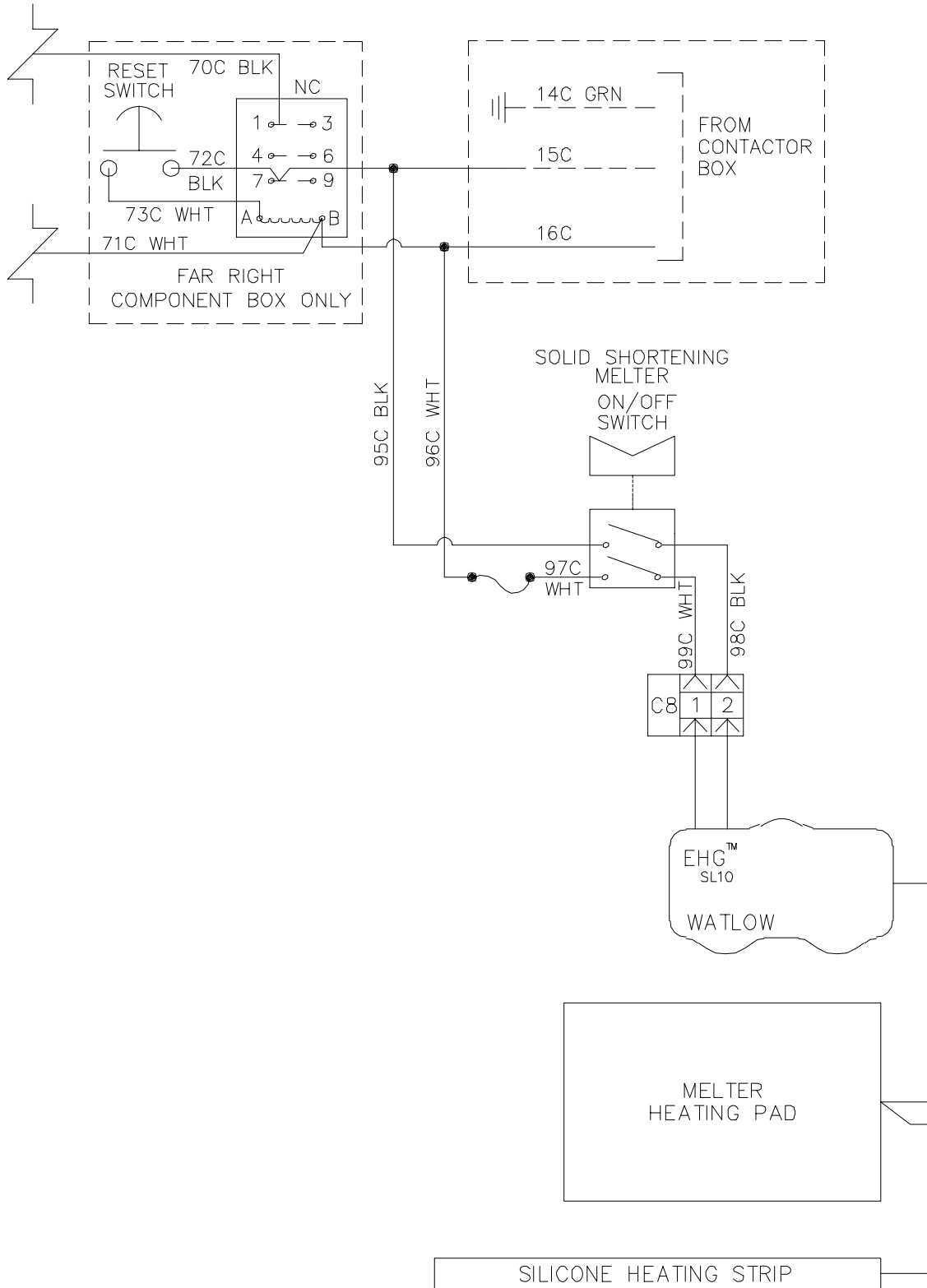

8051889A

1.16.16 Bulk Oil Wiring Diagram

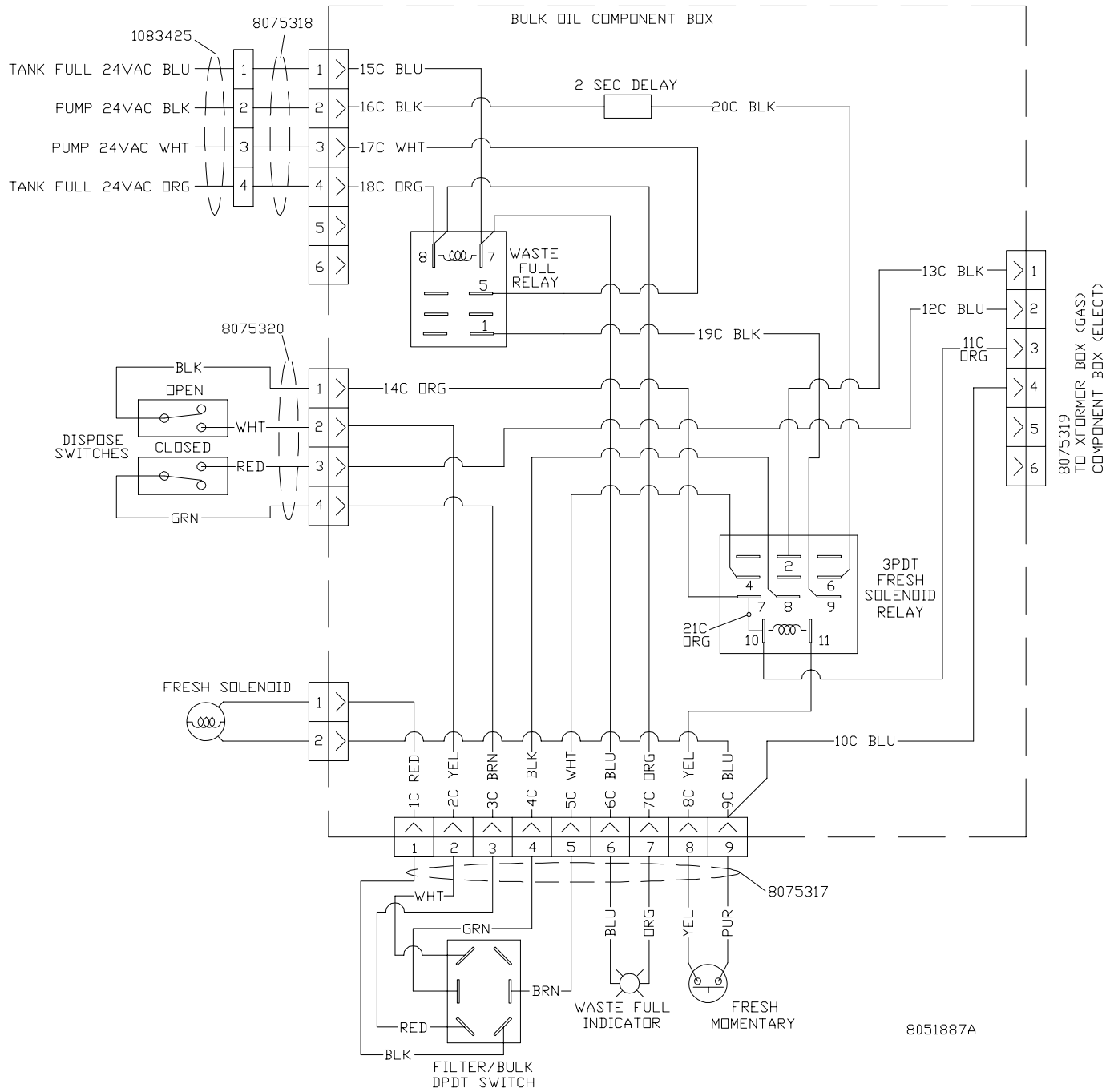

OCF™ SERIES ELECTRIC FRYERS

CHAPTER 2: PARTS LIST

2.1 Accessories

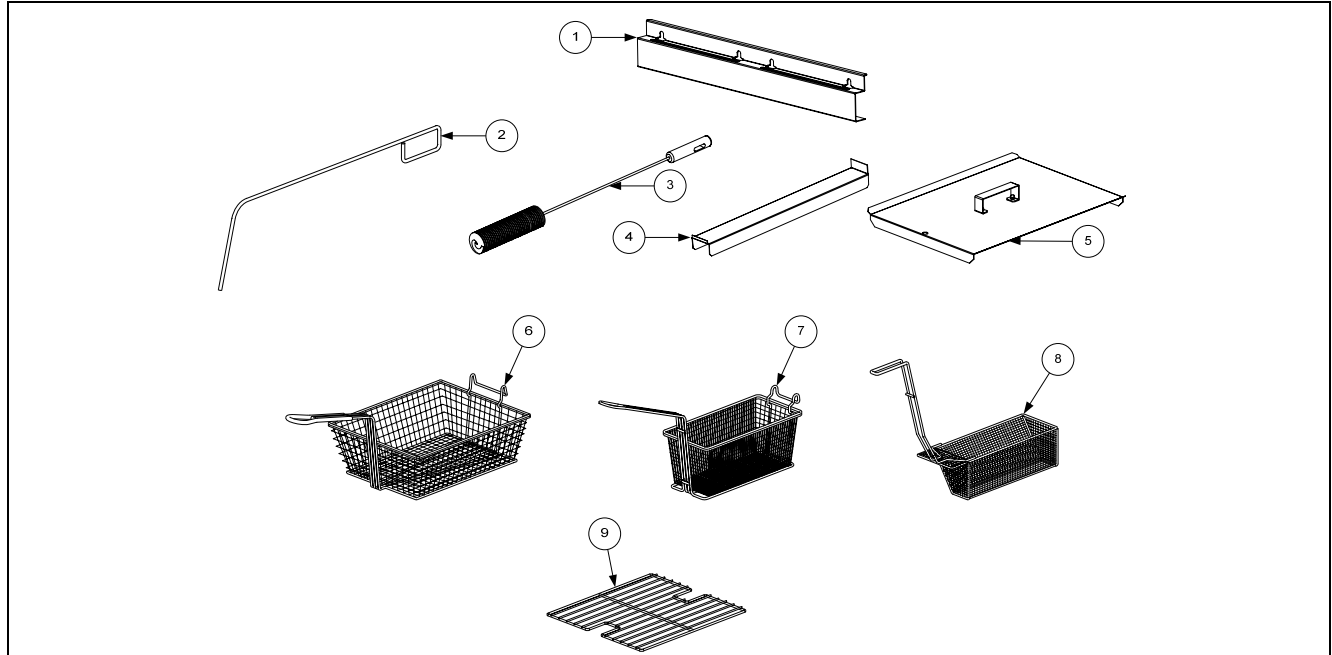

ITEM	PART #	COMPONENT
1	230-8165	Hanger, Basket Single
	230-7495	Hanger, Basket Two Station
	230-7497	Hanger, Basket Three Station
	230-7495 (2)	Hanger, Basket Four Station
2	803-0197	Cleanout Rod, 27-inch
3	803-0398	Brush, Frypot
4	823-7263	Connecting Strip, Frypot
*	823-6755	Connecting Strip, Spreader LH Side <i>(Use 823-6756 for Spreader RH Side)</i>
5	106-8325	Cover, Full-Vat Frypot
	106-8329	Cover, Dual-Vat Frypot
6	803-0099	Basket, Full Size
7	803-0271	Basket, Twin Size
8	803-0113	Sediment Tray, Full Vat
	803-0122	Sediment Tray, Left Dual Vat
	803-0123	Sediment Tray, Right Dual Vat
9	803-0132	Rack, Full-Vat Basket Support
	803-0136	Rack, Dual-Vat Basket Support
*	824-1664	Spreader Pan
*	824-1720	Cover, Spreader Pan
*	803-0002	Powder, Filter (80- 1-Cup Applications)
*	803-0170	Pack, 100-Sheet Filter Paper 19.5X 27.5
*	823-8065	Plate, Fish
*	823-8224	Shield, Splash Frypot

*Not illustrated.

2.2 Basket Lift Assembly and Associated Parts

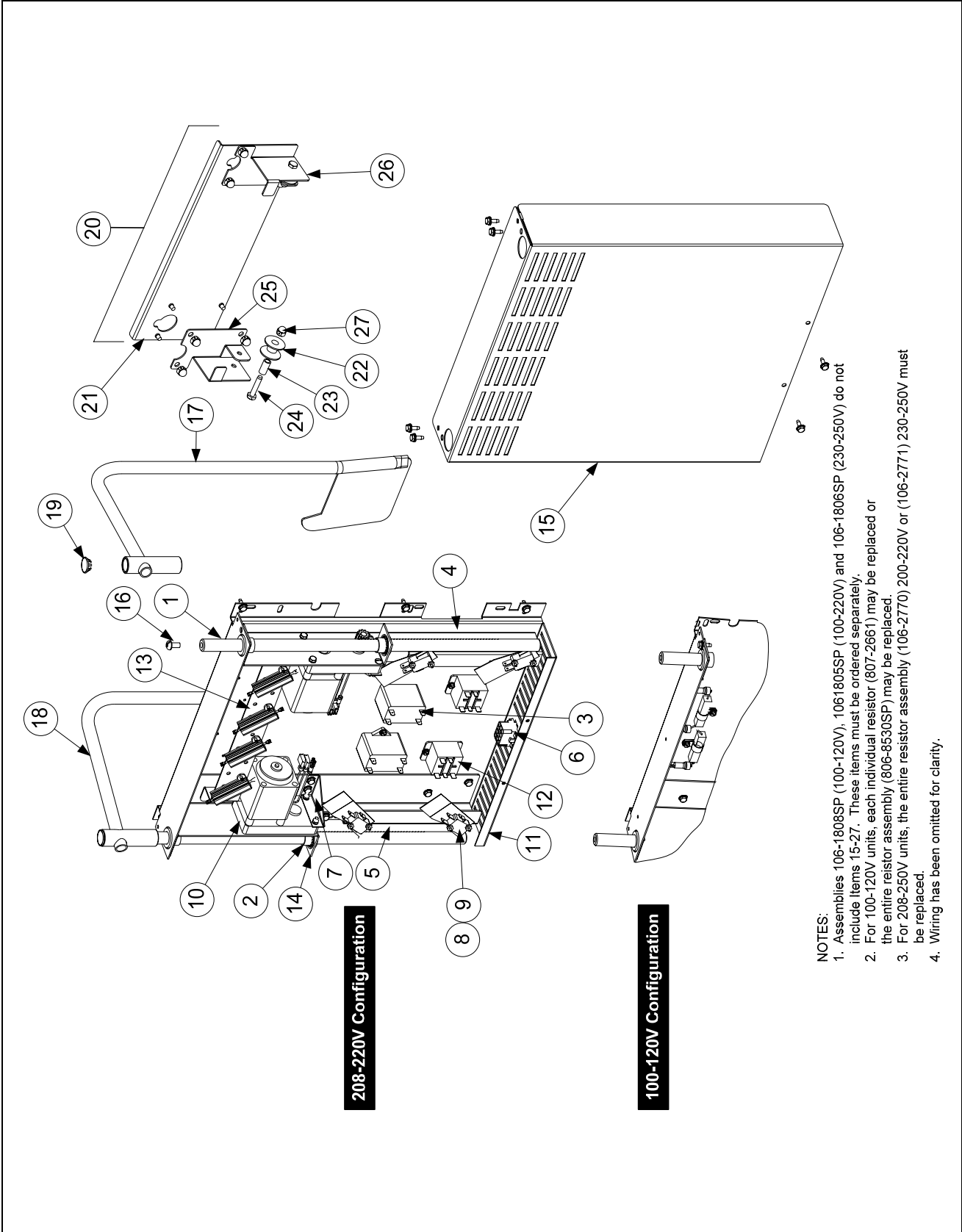

2.2 Basket Lift Assembly and Associated Parts cont.

ITEM	PART #	COMPONENT
		Basket Lift Assemblies (<i>see Note 1 in illustration</i>)
	106-1808SP	Basket Lift Assembly, 100-120VAC w/Relay (<i>Items 1-20</i>) shown
	106-1805SP	Basket Lift Assembly, 200-220VAC w/Relay (<i>Items 1-20</i>) shown
*	106-1806SP	Basket Lift Assembly, 230-250VAC w/Relay (<i>Items 1-20</i>) not shown
1	810-1012	Rod, Basket Lift
2	813-0035	Bushing, Bronze
3	807-2513	Capacitor, 12.5 μ Fd 330VAC
4	901-8499	Chassis, Left Basket Lift
5	902-8499	Chassis, Right Basket Lift
6	807-0159	Connector, 12-Pin Female
7	900-5529	Gusset, Basket Lift Motor
8	812-0442	Insulation, Microswitch
9	807-2572	Microswitch
10	806-5964SP	Motor Assembly, 208-240VAC Modular Basket Lift
11	200-2942	Mount, Modular Basket Lift
12	807-1683	Relay, 12VDC
13		Resistor Assembly
	806-8530SP	100-120V Modular Basket Lift (<i>see Note 2 in illustration</i>)
	106-2770SP	208-220VAC Modular Basket Lift
*	106-2771SP	230-250VAC Modular Basket Lift
14	809-0082	Ring, Bushing Retainer
15	910-4776	Cover, Modular Basket Lift Rear S/S (<i>Use 900-4776 for Mild Steel</i>)
16	809-0127	Screw, ¼-20 X ½-inch Slotted Round Head
17	823-7986	Arm, Left Basket Lift
18	823-7987	Arm, Right Basket Lift
19	810-0179	Button, Plug
20	108-2743SP	Roller Assembly, Basket Lift
21	108-2860	Mount, Basket Lift Roller
22	810-0194	Roller, Basket Lift
23	810-0374	Spacer, Basket Lift Roller
24	809-0508	Bolt, ¼-20 X 1¼ -Inch
25	823-7980	Guide, Basket lift Left
26	823-8023	Guide, Basket lift Right
27	809-0990	Nut, ¼-20 Cap
*	824-1477	Tray, Drip Right
*	824-1476	Tray, Drip Left
		Wire Assemblies
*	WIR-0166SP	Wire Bundle, 200-250VAC Basket Lift w/Relay
*	106-5962	Wiring Harness, RE Series Electric Basket Lift (<i>Plugs into Item 6</i>)
*	106-6640	Wiring Harness, RE Series Electric Basket Lift SSR (<i>Plugs into Item 6</i>)

* Not illustrated.

2.3 Doors, Sides, Tilt Housings, Top Caps and Casters

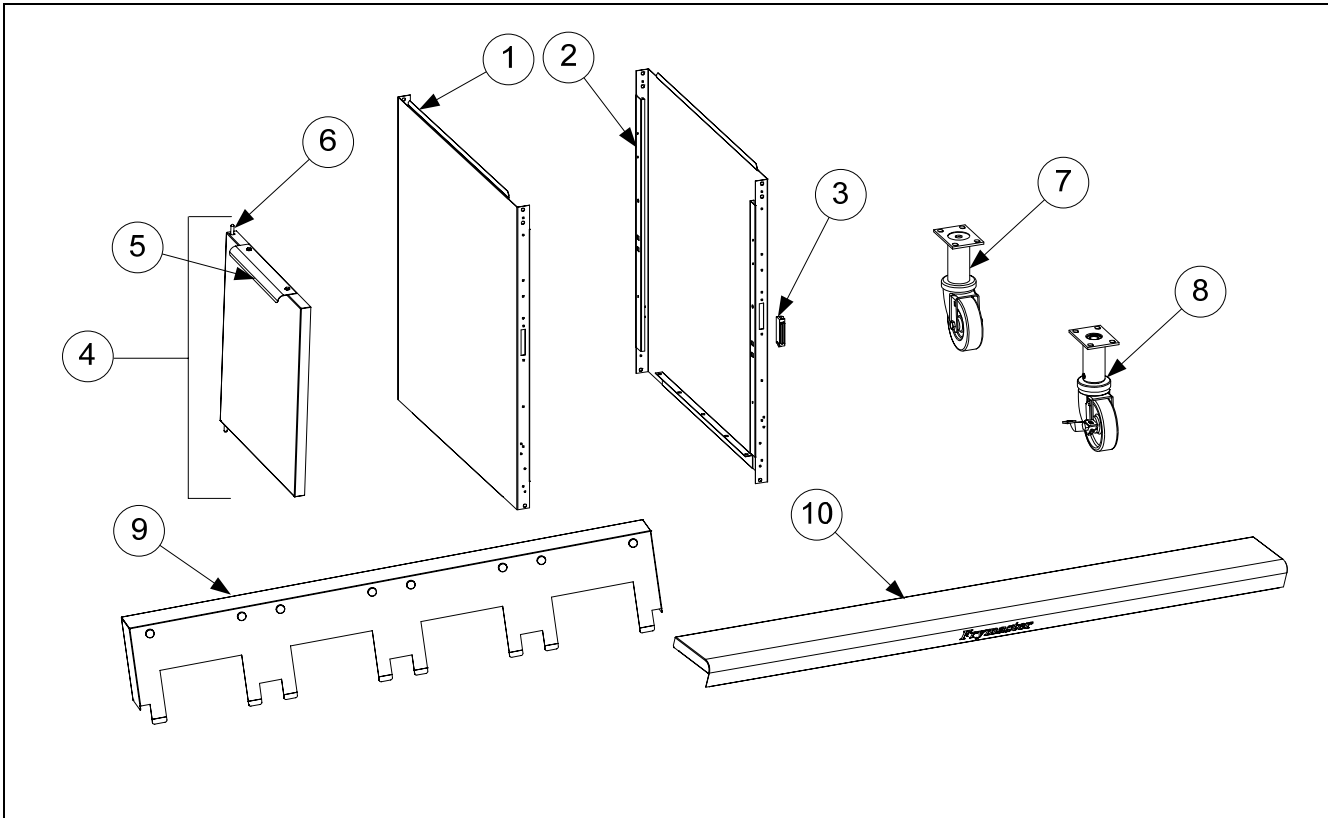

ITEM	PART #	COMPONENT
1	231-0323	Side, Standard Cabinet Left SS (use 221-0323 for Enameled Steel)
2	232-0323	Side, Standard Cabinet Right SS (use 222-0323 for Enameled Steel)
3	810-1105	Magnet, Door (vertical) (use 810-2346 for horizontal over filter pan)
4	106-4397	Door, Left or Right (Left shown – move handle to bottom for right)
5	230-4960	Handle, Door
6	106-4067	Pin Assembly, Door
*	810-0275	Spring, Door Pin
*	809-0970	Retaining Ring
*	230-7192	Hinge, Door Lower
*	210-8288	Panel, Universal Door
*	220-6097	Holder, Manual
7	810-0327	Caster adjustable 4" without Brake
8	810-0944	Caster adjustable 3" with Brake
9	823-7934	Tilt Housing Single (Housing for four station fryer shown)
	823-7891	Two Station, S/S
	823-7892	Three Station, S/S
	823-7893	Four Station, S/S
10	108-2551	Top Cap Single
	106-7835	Two Station (<i>Also requires four 809-0078 10-32 Nutserts</i>)
	106-5979	Three Station (<i>Also requires six 809-0078 10-32 Nutserts</i>)
	106-7576	Four Station (<i>Also requires eight 809-0078 10-32 Nutserts</i>)

* Not illustrated.

2.4 Drain System Components

2.4.1 Drain Tube Sections and Associated Parts

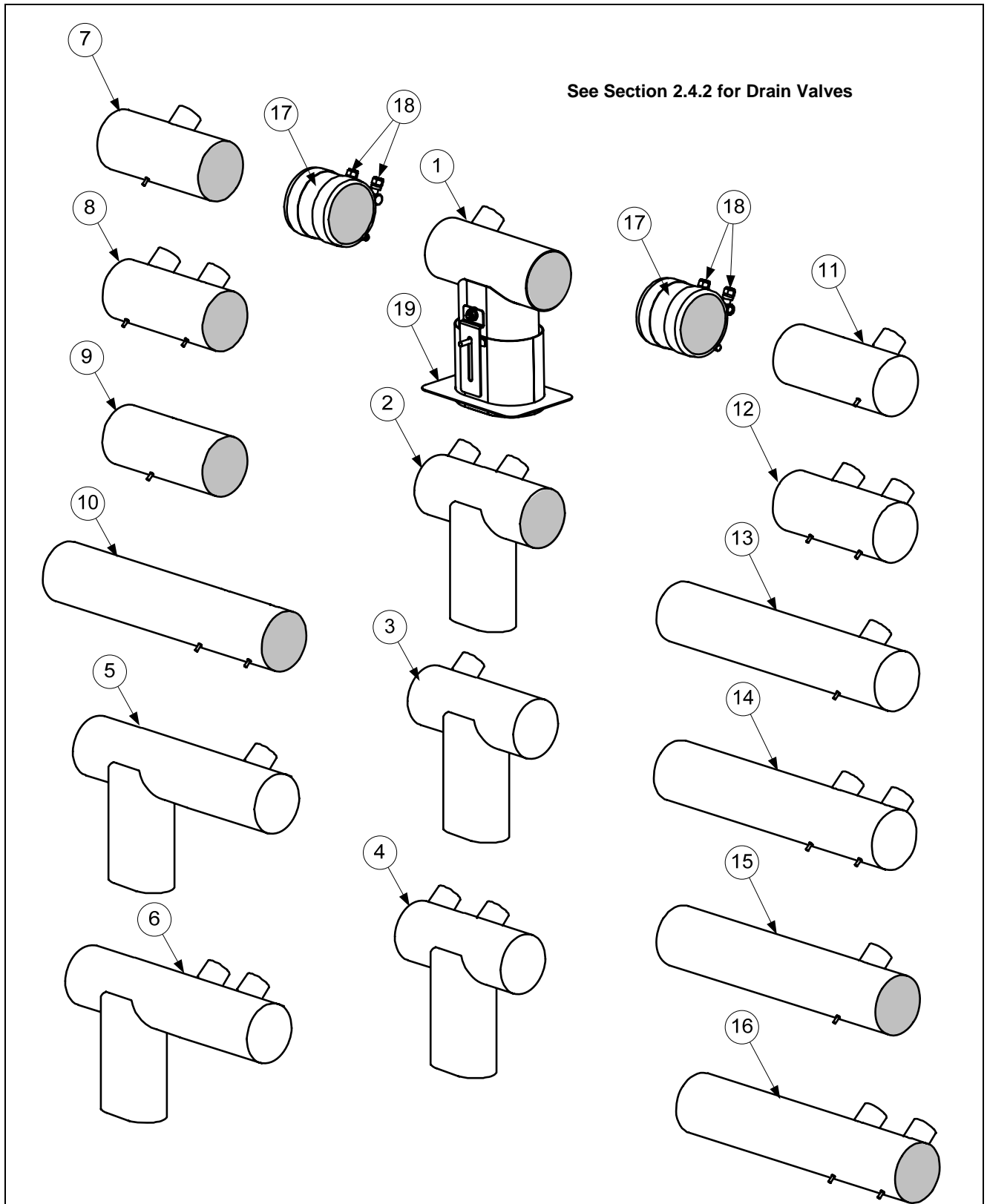

2.4.1 Drain Tube Sections and Associated Parts cont.

ITEM	PART#	COMPONENT
1	823-8141	Drain Tube, Dump Full-Vat Left Closed/Right End Open
2	823-8142	Drain Tube, Dump Dual-Vat Left Closed/Right End Open
3	823-8143	Drain Tube, Dump Full-Vat Left Closed Both Ends
	823-7939	Drain Tube, Dump Single Full-Vat Left Closed Both Ends
4	823-8144	Drain Tube, Dump Dual-Vat Left Closed Both Ends
	823-7936	Drain Tube, Dump Single Dual-Vat Left Closed Both Ends
5	823-8145	Drain Tube, Dump Full-Vat Left Closed Both Ends
*	823-8128	Drain Tube, Dump Full-Vat Left Closed/Right End Open
6	823-8146	Drain Tube, Dump Dual-Vat Left Closed Both Ends
*	823-8129	Drain Tube, Dump Dual-Vat Left Closed/Right End Open
7	823-4643	Drain Tube, Full-Vat, Short, Open Both Ends
8	823-7905	Drain Tube, Dual-Vat, Short, Open Both Ends
9	810-3550	Drain Tube, Short, Open Both Ends
10	810-3551	Drain Tube, Long, Open Both Ends
11	823-4625	Drain Tube, Short Full-Vat Left Open/Right End Closed
12	823-7906	Drain Tube, Short Dual-Vat Left Open/Right End Closed
13	823-4639	Drain Tube, Long Full-Vat Left Open/Right End Closed
14	823-7908	Drain Tube, Long Dual-Vat Left Open/Right End Closed
15	823-4641	Drain Tube, Long Full-Vat Open Both Ends
16	823-7907	Drain Tube, Long Dual-Vat Open Both Ends
17	816-0772	Sleeve
18	809-0969	Clamp
*	816-0630	Vinyl Cap
*	811-1071	Tubing, 1/4-inch OD Teflon Vent (sold by the foot)
19	823-7915	Guard, Filter Lid Splash

* Not illustrated.

2.4.2 Drain Valve Assembly

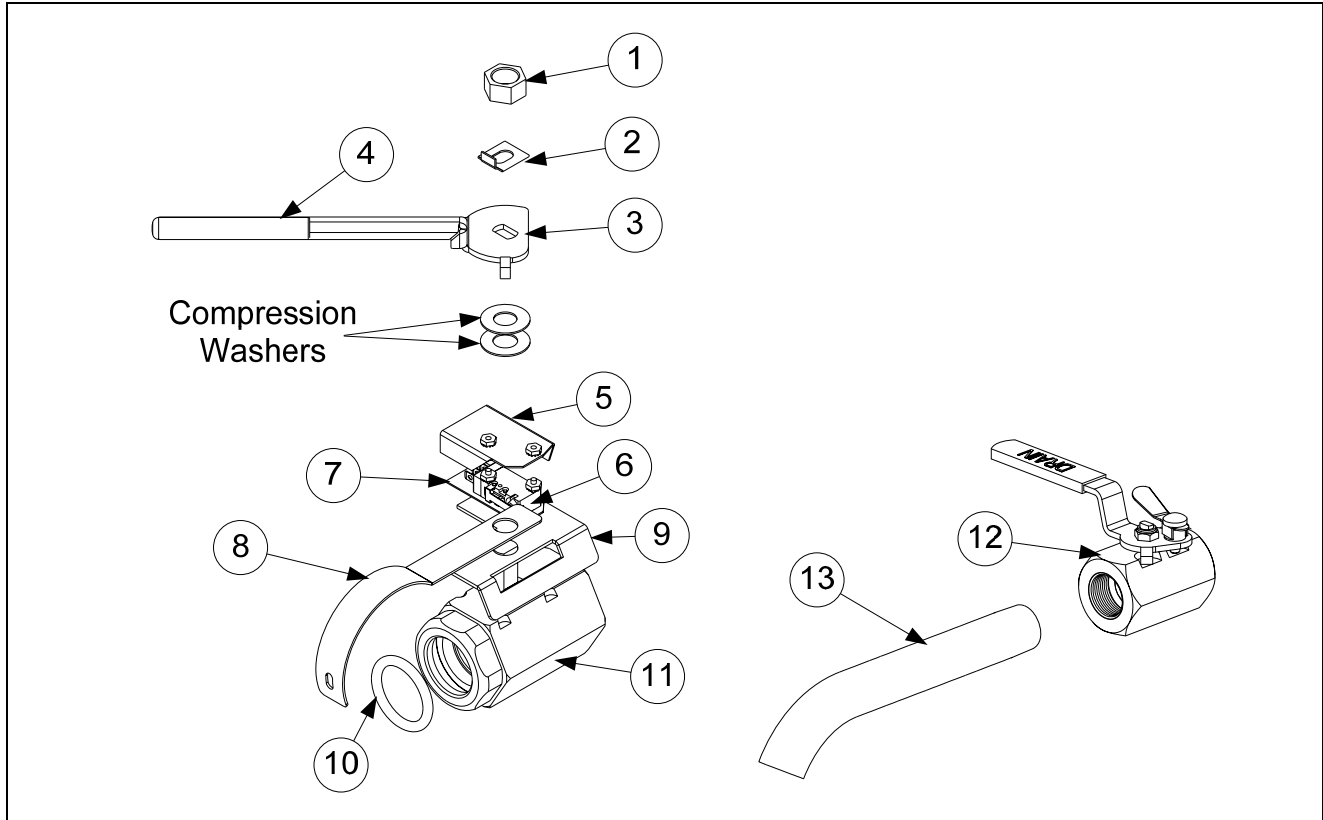

ITEM	PART #	COMPONENT
	108-2451	Valve, Assembly Drain FV OCF with Filter
	108-2452	Valve, Assembly Drain DV OCF with Filter
	108-2593	Valve, Assembly Drain FV OCF Single with Filter
	108-2450	Valve, Assembly Drain DV Right OCF Single with Filter
	108-2449	Valve, Assembly Drain DV Left OCF Single with Filter
1	809-0540	Nut, ½-13 2-Way Hex Lock
2	900-2936	Retainer, Nut Drain Valve
3	824-2188	Handle, Drain Valve FV, FV Single and DV Single Left with Filter
	824-2189	Handle, Drain Valve DV and DV Single Right With Filter
4	816-0639	Cap, Vinyl Red
5	901-2348	Cover, Safety Switch
6	807-4936	Switch, Micro Gold Plated
7	816-0220	Insulation, RF Switch
8	200-6496	Support, Drain Tube
	220-8162	Bracket, Single 1¼-inch Drain Valve (used on FV Single with Filter)
9	108-2453	Bracket Assy, Drain Switch
10	816-0135	O-Ring, Round Drain Seal
11	810-1018	Valve, 1¼-inch Drain with Filter
12	810-1569	Valve, 1¼-inch Drain Non-Filter
13	812-1226	Drain Extension 1¼-inch (<i>use with 810-1569</i>)
*	807-5159	Harness, Drain FV (<i>connects from drain switch to rear of controller</i>)
*	807-5160	Harness, Drain DV (<i>connects from drain switch to rear of controller</i>)

2.5 Electronics and Wiring Components

2.5.1 Component Boxes

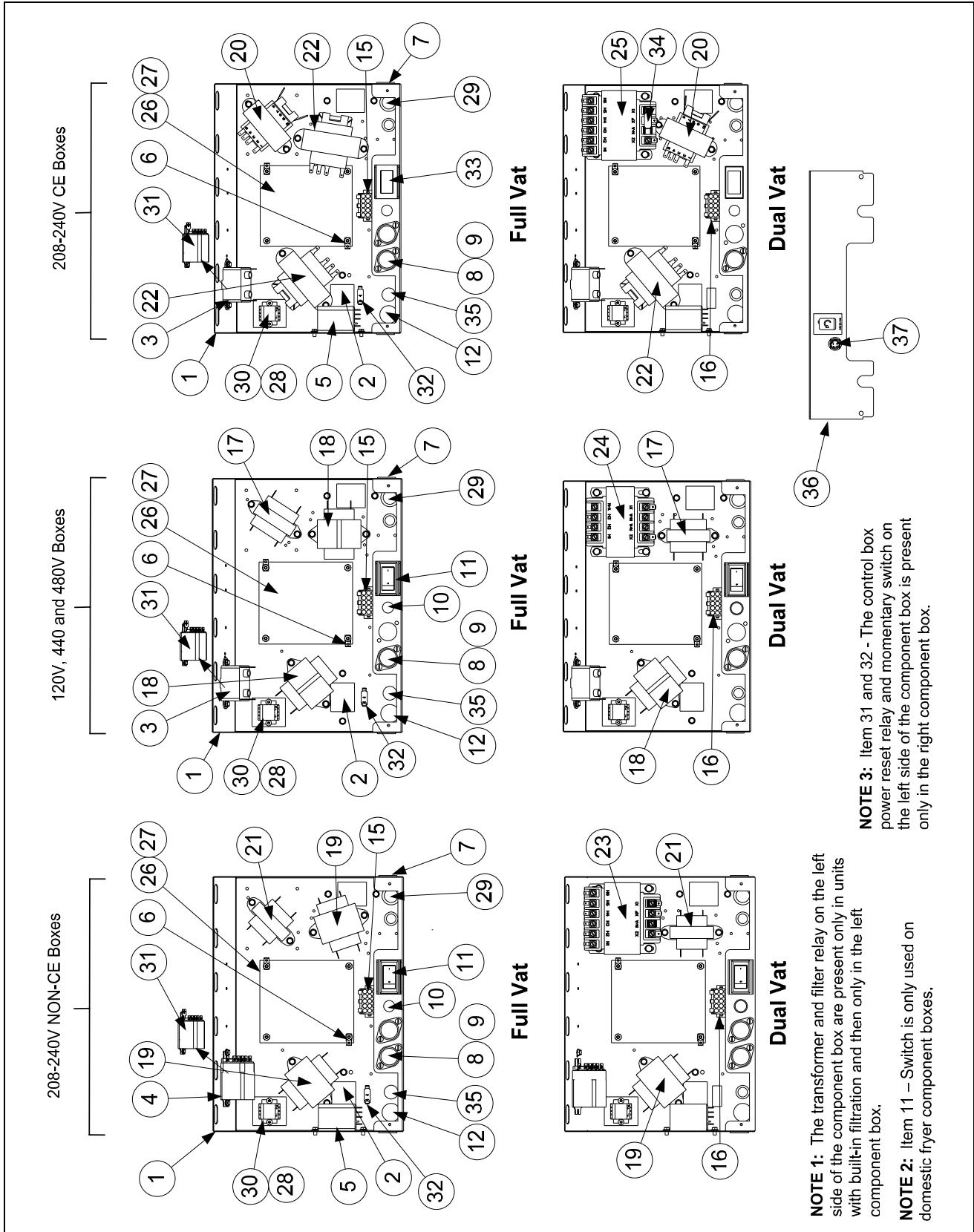

2.5.1 Component Boxes cont.

ITEM	PART #	COMPONENT
1	106-5592	Box Assembly, Component
2	200-3300	Bracket, Component Box Strain Relief
√ 3	807-0012	Relay, Filter 18A, 1/3HP 24VAC
√ 4	807-0670	Relay, Filter DPDT 20A 24VAC
√ 5	807-4770	Relay, 240V DPDT 20A
√	807-4346	Relay, 120V DPDT 20A (<i>used in Canadian models only</i>)
6	807-0037	Terminal, ¼-inch Push-on
7	807-0121	Bushing, Heyco Plastic AB-625-500
8	807-0922	Holder, Buss Fuse HPS Screw Type
√ 9	807-2278	Fuse, 20 Amp
10	810-2446	Plug, Button .50 Heyco Double "D"
√ 11	807-4036	Switch, Power
	807-3575	Plug, Carling Switch Hole (<i>used on some models without a switch</i>)
12	807-1947	Plug, Button .875 Dome
13	807-1321	Holder, AGC Panel Mount ¼" Fuse (<i>Some models use item 10 here.</i>)
14	807-1597	Fuse, 3 AMP Slow-Blow
15	106-5750	Harness Assembly, RE FV Control
16	106-5751	Harness Assembly, RE DV Control
√ 17	807-0855	Transformer, 100-120V 12V 20VA
√ 18	807-0800	Transformer, 100-120V 24V 50VA Filter
√ 19	807-0680	Transformer, 208-240V 24V 20VA Filter
√ 20	807-2191	Transformer, 208-240V 12V 30VA
√ 21	807-0979	Transformer, 208-240V 12V 43VA
√ 22	807-2180	Transformer, 100-120V 50VA Filter
√ 23	812-2126	Transformer, 208-250V 24V 75VA w/o Fuse (<i>Used in DV component boxes</i>)
√ 24	807-4967	Transformer, 100-120V 24V 75VA (<i>Used in DV component boxes</i>)
√ 25	807-4968	Transformer, 208-250V 24V 75VA (<i>Used in DV component boxes</i>)
√ 26	826-2260	Interface Board Standard Full or Dual Vat (<i>includes sound harness</i>)
*	106-6501	Fallback Controller Assembly
*	807-4403	Speaker, 4-Watt SMT
27	809-0349	Spacer, 4mm X 6mm Aluminum
28	816-0217	Paper, Insulating Terminal Block
29	810-0045	Bushing, .875 Diameter 11/16"
30	806-9495SP	Terminal Block
√ 31	807-4346	Relay, DPDT 20A 120V (<i>used for control power reset in right hand boxes only in domestic and Canadian units</i>)
√	807-4770	Relay, DPDT 20A 240V (<i>used for control power reset in right hand boxes only in international units; some international units have one located in each control box</i>)
32	807-2659	Switch, Momentary (<i>used to reset control power; located in box over JIB only.</i>)
33	230-5038	Guard, Switch
√ 34	807-1174	Fuse, 250V 3 AMP Slow-Blow
35	810-2445	Plug, Button .625 Heyco Double "D"
36	220-8467	Guard Finger OCF with JIB (<i>use 220-5038 for OCF without JIB</i>)
√ 37	807-4678	Switch, Momentary JIB Reset
*	826-2249	RE Hood/Ansul Interlock Kit (includes terminal block, wires and connectors)

* Not illustrated.

√ Recommended parts.

2.5.2 Contactor Boxes

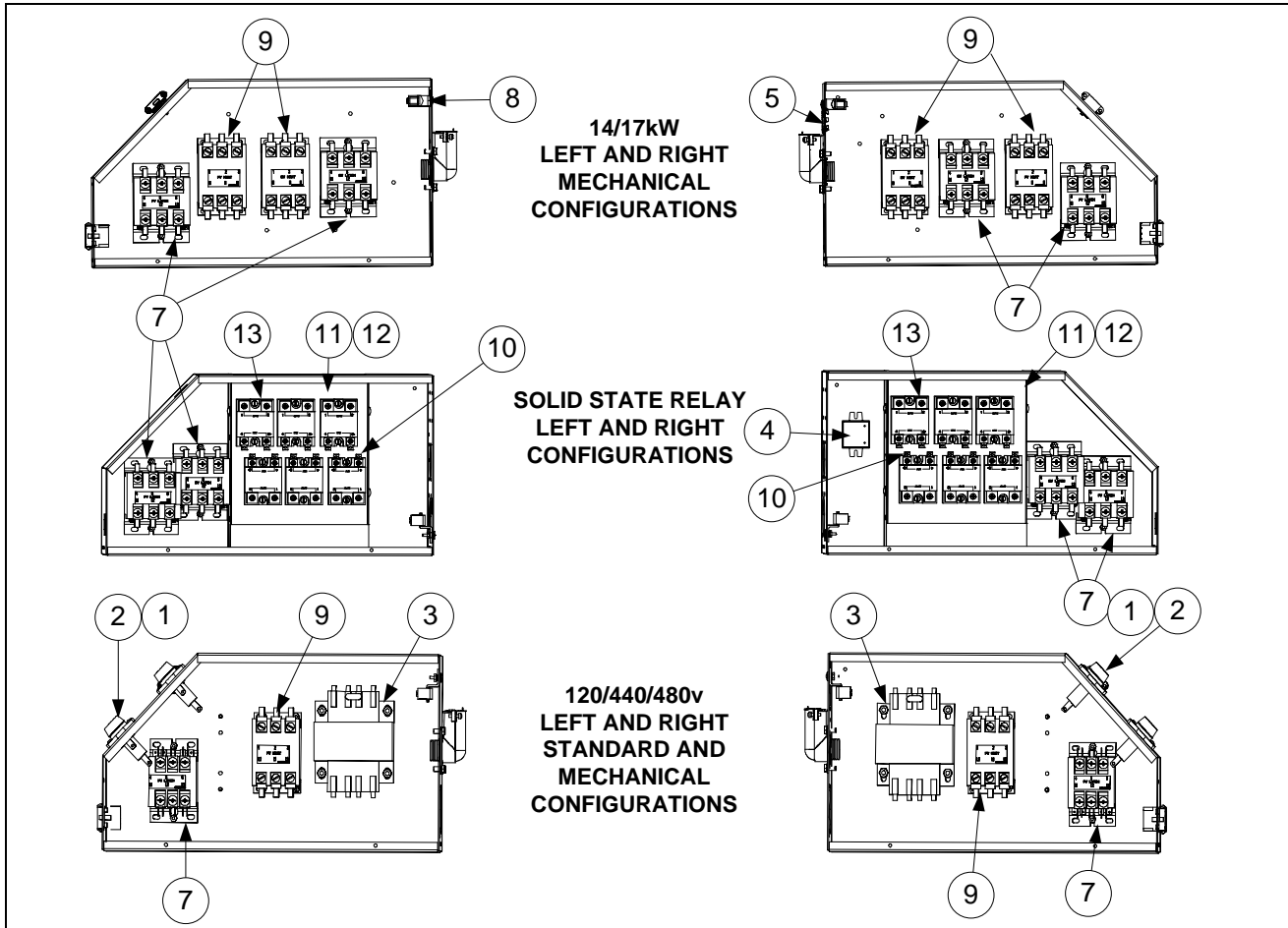

NOTES: The configurations illustrated show all possible components, but a particular configuration may not have all the components shown.

ITEM	PART #	COMPONENT
1	807-2278	Fuse, 20 Amp
2	807-0922	Holder, Bus Fuse
3	807-0064	Transformer, 480V/120V 150VA
4	106-6204	Filter Assembly, EPRI (Used on some CE WYE configurations)
5	810-2554	Plug, Cord Cutout 1.125 Button
6	807-1947	Plug, .875 Diameter Dome
7	810-1202	Contactor, 24V 40 Amp Mechanical (<i>Latch</i>)
8	807-0070	Terminal, Ground Lug
9	807-2284	Contactor, 24V 50 Amp Mechanical (<i>only in 14kW & 17kW units</i>) (<i>Heat</i>)
10	807-0037	Terminal, ¼-inch Push-on
11**	806-8673	Heatsink Assembly, FV Solid State Relay (See components below)
		Components of Items 12 and 13
12	826-1562	Kit Relay, Solid State 40 Amp 280V with Heatsink
13	807-2749	Heatsink, Solid State
*	221-0482	Cover, Left Contactor Box
*	222-0482	Cover, Right Contactor Box
*	807-0012	Relay, Tilt Switch 18 Amp 1/3 HP 24 V Coil

* Not illustrated. ** Full Vat has three relays 826-1562, Dual-Vat has six relays.

2.5.3 Fuse Boxes

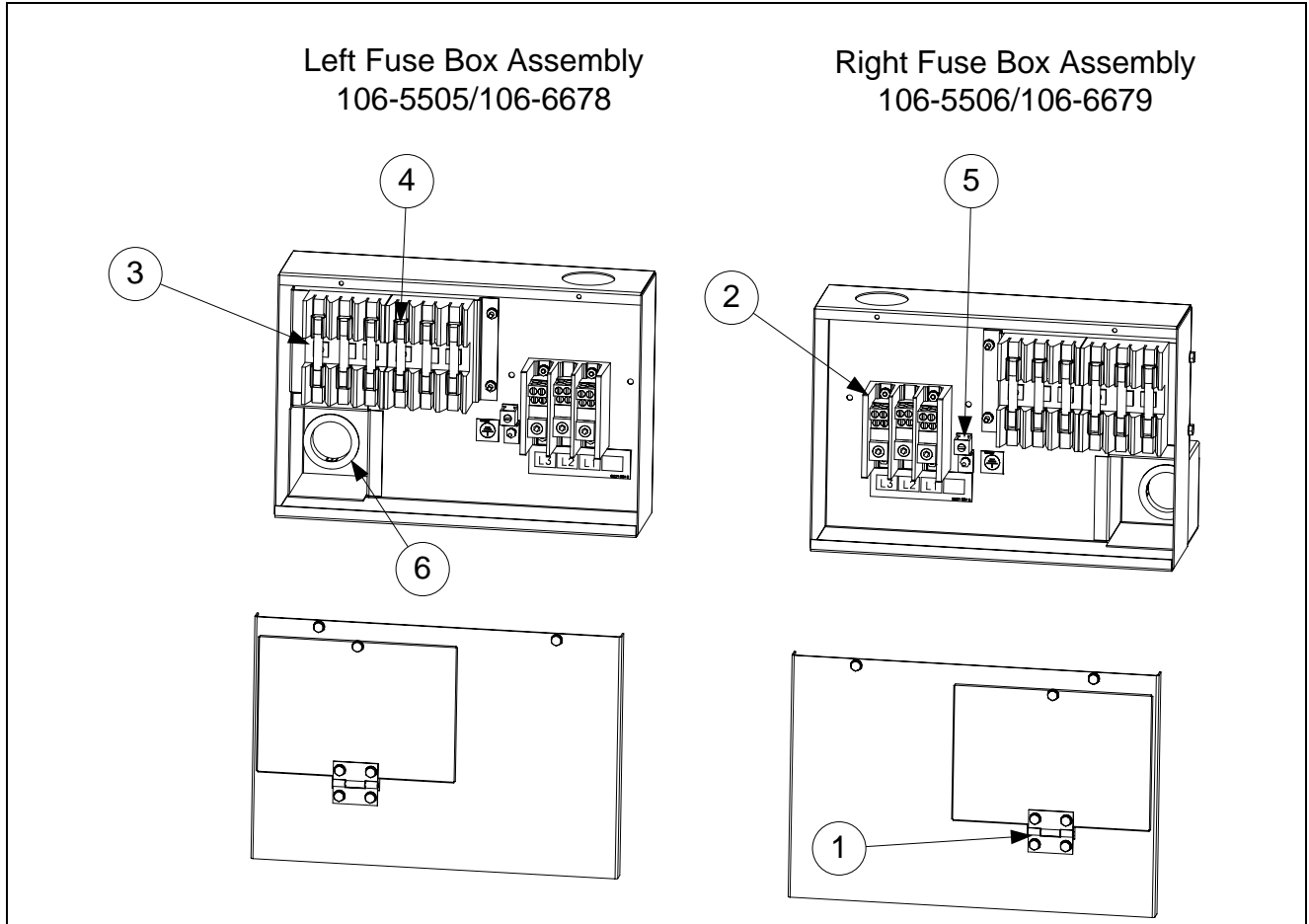

ITEM	PART #	COMPONENT
1	810-0519	Hinge
2	807-3970	Block, 3 Pole 600V 175A Terminal
3	807-0501	Fuse Block, Buss #2968 3-Pole
4	807-2240	Fuse, 60 AMP 300VAC
5	807-0070	Terminal, Ground Lug
6	807-0128	Bushing, Insulating Heyco

2.5.4 Terminal Blocks

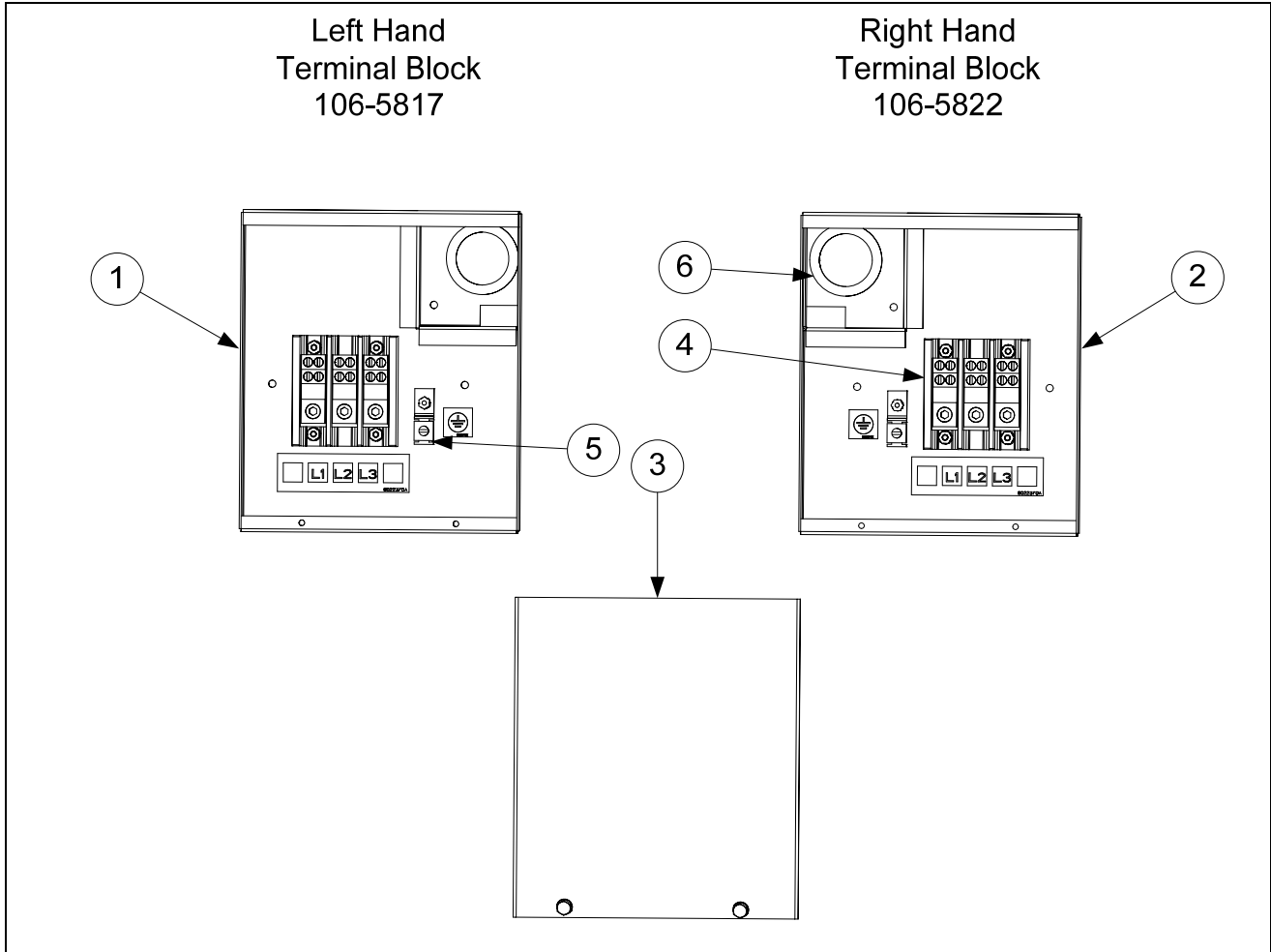

ITEM	PART #	COMPONENT
1	823-5631	Box, LH Rear Terminal Block
2	823-5632	Box, RH Rear Terminal Block
3	220-0801	Cover, Rear Terminal Block Box
4	807-3970	Block, 3 Pole 600V 175A
5	807-0070	Terminal, Ground Lug
6	807-0128	Bushing, Insulating Heyco

2.5.5 Heating Element Assemblies and Hardware

FULL-VAT ELEMENT ASSEMBLY

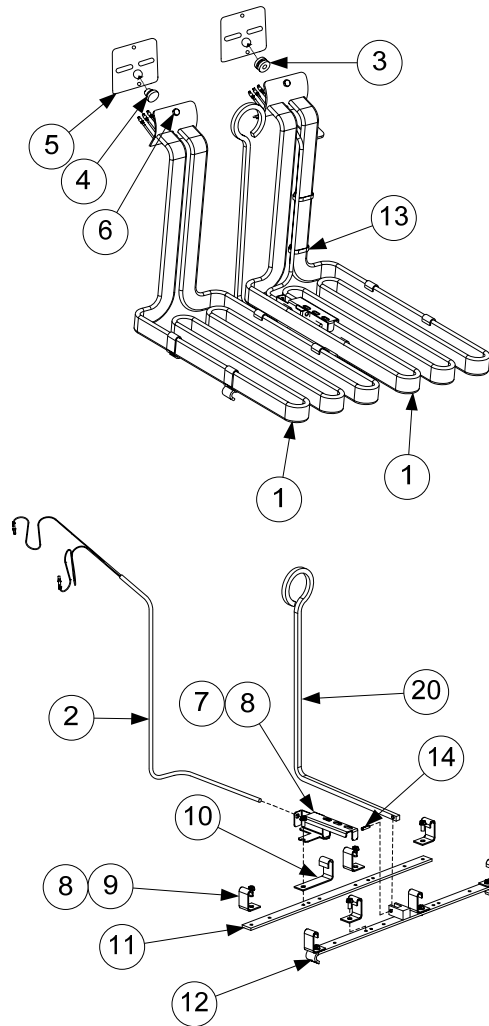

DUAL-VAT ELEMENT ASSEMBLY

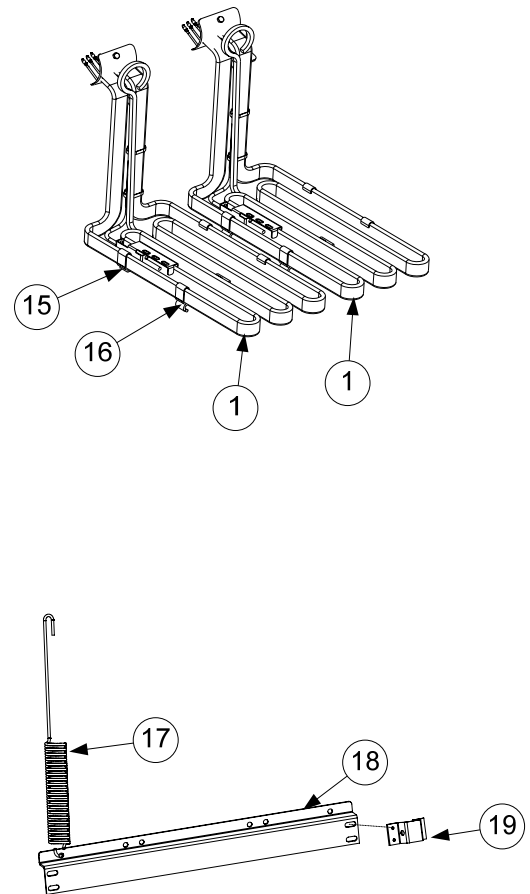

NOTES:

The dual-vat assembly is almost the same as the full-vat assembly except for having two of Items 2, 3, 7, 14, 15, 16 and 20. The only difference between element assemblies for different voltage and kW ratings is the element itself (Item 1).

Items 17, 18 and 19 are shown as associated parts. They are not part of either assembly.

NOTE: These elements apply only to FPEL series fryers.

2.5.5 Element Assemblies and Hardware cont.

ITEM	PART #	COMPONENT
1		Element Kits – <i>includes gaskets, grommets, tie wraps, screws and nuts.</i>
	826-2198	200V 7.0 kW (220V 8.5kW used in some export 3-phase 4-wire WYE units)
	826-2201	200V 8.5 kW
	826-2192	208V 7.0 kW
	826-2197	208V 8.5 kW
	826-2200	220V 7.0 kW (220V 8.5kW used in some export 3-phase 4-wire WYE units)
	826-2193	230V 7.0 kW
	826-2199	230V/400V 7.0 kW/8.5 kW(220V 8.5kW used in some export 3-phase 4-wire WYE units)
	826-2194	240V 7.0 kW
	826-2204	400V 8.5kW
	826-2195	440V 7.0 kW
	826-2202	440V 8.5 kW
	826-2196	480V 7.0 kW
	826-2203	480V 8.5 kW
√ 2	826-2212	Probe, Temperature RE – <i>includes tie wraps and grommet.</i>
	807-4324	Probe, Temperature Fast Ready
3	816-0681	Grommet, Probe
4	816-0480	Plug, .375-inch Dome
5	816-0688	Gasket, Element
6	809-1003	Screw, 10-32 X 3/8-inch Hex Head SS
*	809-0766	Nut, 10-32 Keps Hex Head SS
*	230-4028	Wrench, Element Tube Nut Spanner
7	230-3714	Bracket, Temperature Probe 7.0 kW
	230-0784	Bracket, Temperature Probe 8.5
8	809-0518	Screw, 8-32 X 3/8-inch Slotted Hex Head
9	910-2042	Clamp, Element (Short)
10	230-0781	Clamp, Element (Long)
11	230-0780	Support, Full-Vat Element Rear
12	823-5621	Support, Full-Vat Element Front
13	809-0567	Tie-Wrap, Metal
14	810-1212	Pin, .125 X .5-inch Split
15	230-4903	Support, Dual-Vat Element Rear Dual Vat
16	823-8085	Support, Dual-Vat Element Front Dual Vat 14kW (230-8566 McD only)
	823-8086	Support, Dual-Vat Element Front Dual Vat 17kW
17	810-3030	Spring, Element Lift Left
	810-3131	Spring, Element Lift Right
18	220-1190	Bracket, Lower Spring Single Foot Print
	220-0464	Bracket, Lower Spring
19	220-0733	Bracket, Lower Spring Mating
20	810-1233	Handle, Element Lift

* Not illustrated.

√ Recommended parts.

2.5.6 Element Tube Assemblies

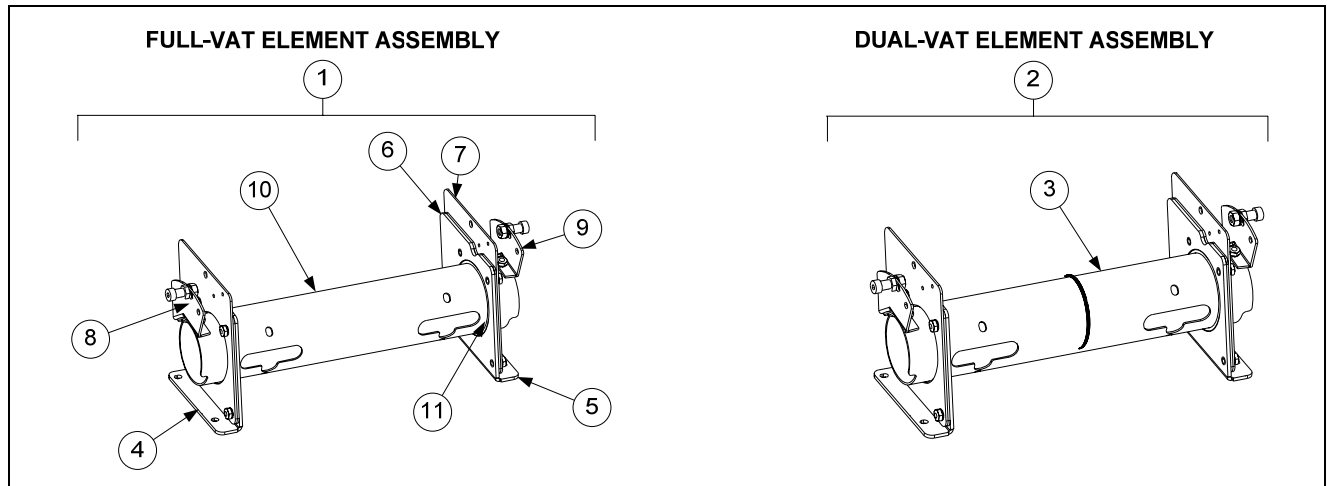

ITEM	PART #	COMPONENT
1	108-0297SP	Tube Assembly, Full-Vat 14kW
	108-0293	Tube Assembly, Full-Vat 17
2	108-0298SP	Tube Assembly Dual-Vat 14kW
	108-0295	Tube Assembly Dual-Vat 17
3	810-3246	Bushing and Tube Assembly, Dual-Vat
4	108-0315	Bracket Assembly, LH Element Tube Support
5	108-0316	Bracket Assembly, RH Element Tube Support
6	220-0122	Plate, Element Tube Support Inner
7	220-0123	Plate, Element Tube Support Outer
8	106-7651	Bracket Assembly, LH Upper Spring (<i>use 106-6569 for 17kW</i>)
9	106-7652	Bracket Assembly, RH Upper Spring (<i>use 106-6570 for 17kW</i>)
10	810-2992	Tube, Full Vat Element Mounting
11	810-2993	Bushing, Tube End Teflon
*	826-2598	Kit, Tilt Switch
*	807-4742	Switch, Long Lever High Temp

* Not illustrated.

2.5.7 Controllers

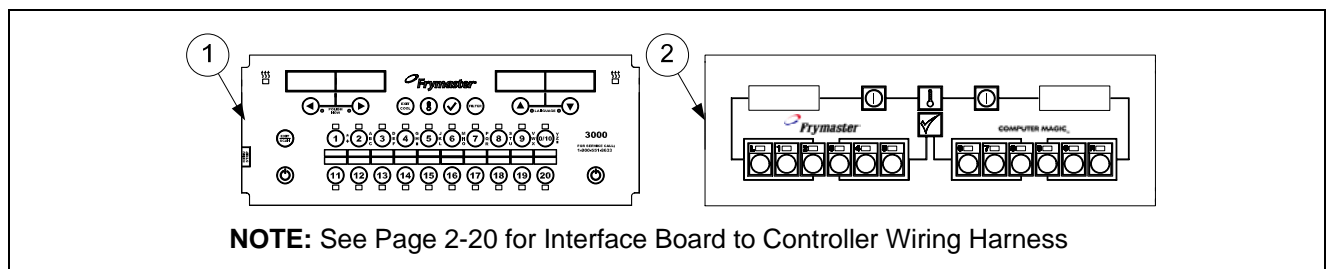

ITEM	PART #	COMPONENT
√ 1	108-2399SP	Replacement 3000 Controller
√ 2		Replacement CM 3.5 Controller
	826-2395	Non-CE CM3.5 (<i>For use in US, Canada, Mexico and all other non-CE countries</i>)
	826-2332	CE CM3.5 (<i>For use in European CE countries</i>)
	810-3141	Sound Device, Universal SMT

√ Recommended parts.

2.5.8 Wiring

2.5.8.1 Contactor Box Wiring Assemblies – 12-Pin Dual-Vat C-1

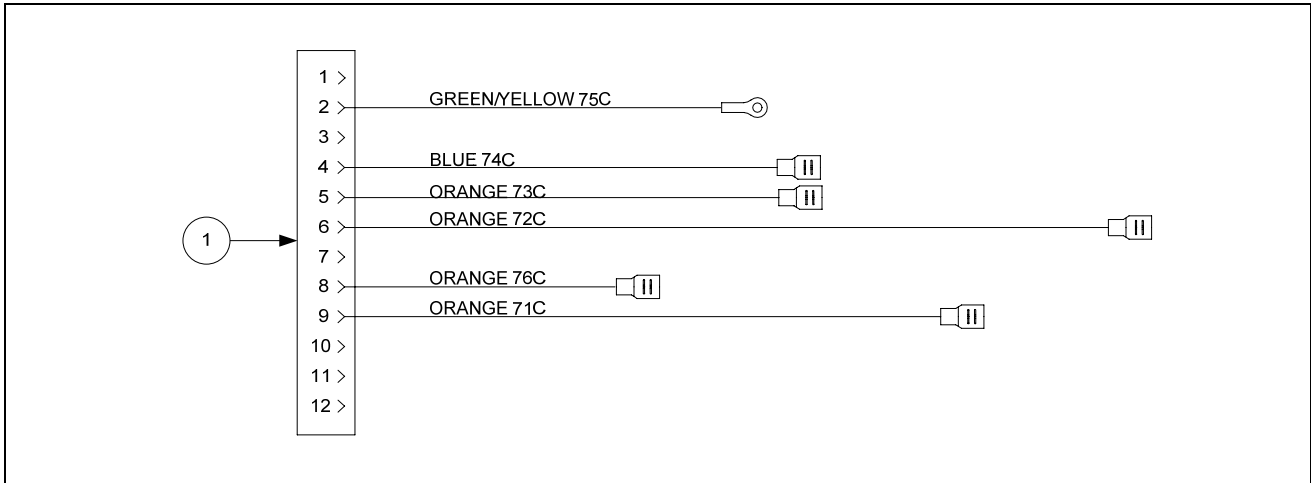

ITEM	PART #	COMPONENT
1	106-5980SP	Contactor Box Harness Assembly Dual Vat Standard (See wiring diagrams on pages 1-35 thru 1-36.)

2.5.8.2 Contactor Box Wiring Assemblies – 12-Pin Full-Vat C-1

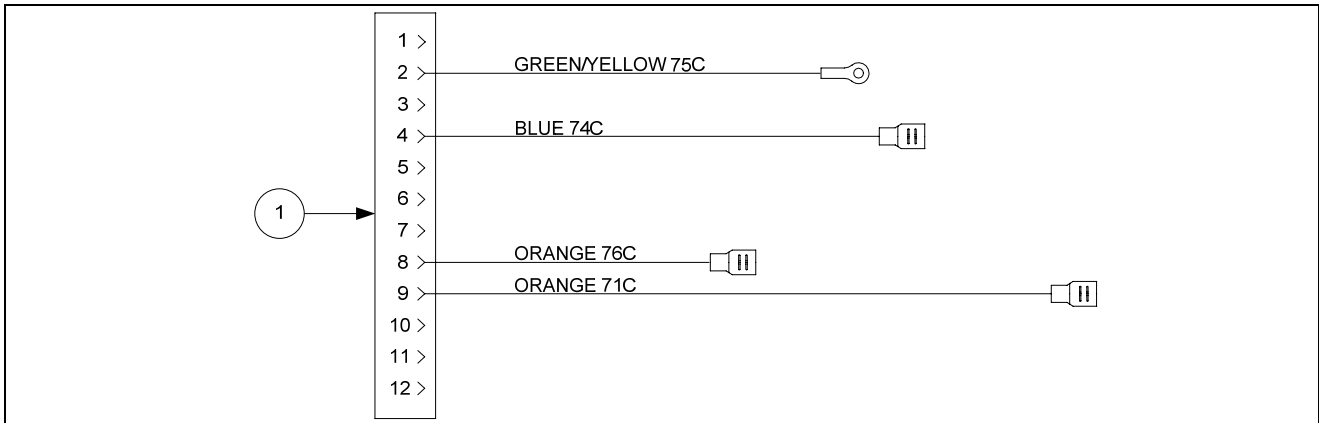

ITEM	PART #	COMPONENT
1	106-6031SP	Contactor Box Harness Assembly Full Vat Standard (See wiring diagrams on pages 1-35 thru 1-36.)

2.5.8.3 Contactor Box Wiring Assembly – 6-Pin (Left Element)

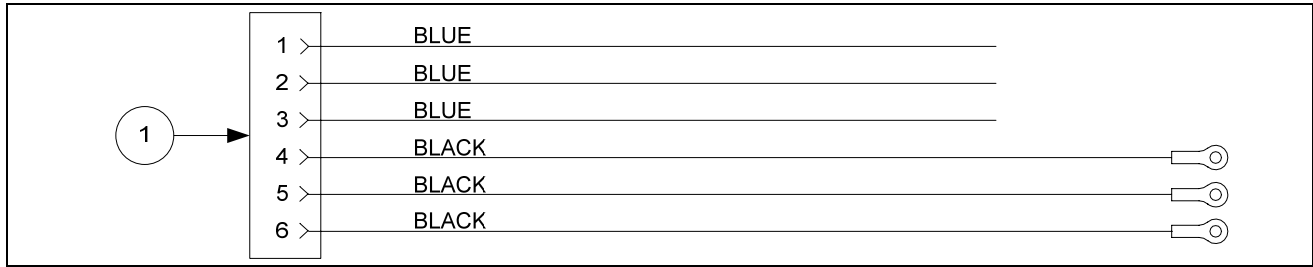

ITEM	PART #	COMPONENT
1	106-8744SP	14/17 kW Mechanical Contactor
	106-7851SP	High Amp Mechanical Contactor

2.5.8.4 Contactor Box Wiring Assembly – 9-Pin (Right Element)

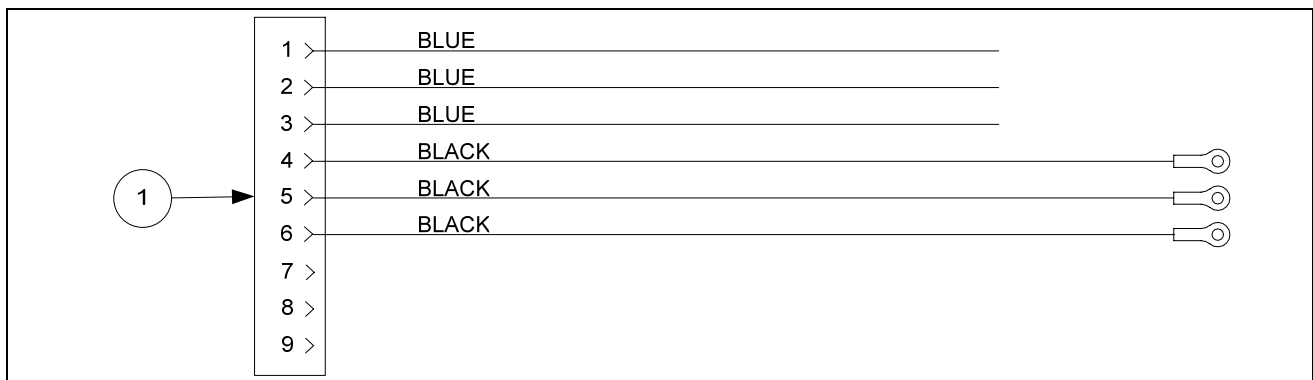

ITEM	PART #	COMPONENT
1	106-8745SP	14/17 kW Mechanical Contactor
	106-7852SP	High Amp Mechanical Contactor

2.5.8.5 Main Wiring Harnesses

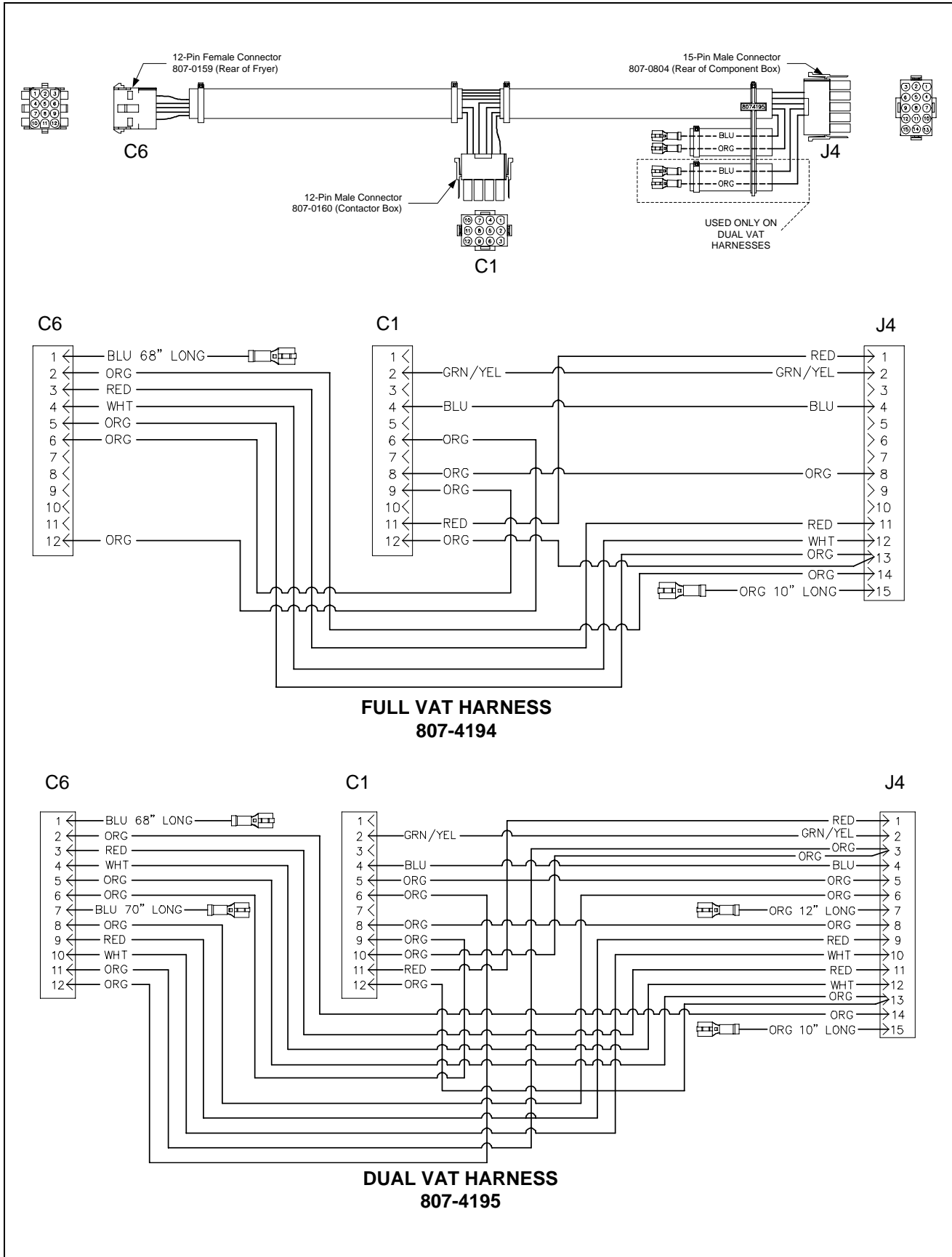

2.5.8.6 Component Box, Filter Pump and Basket Lift Wiring Harnesses

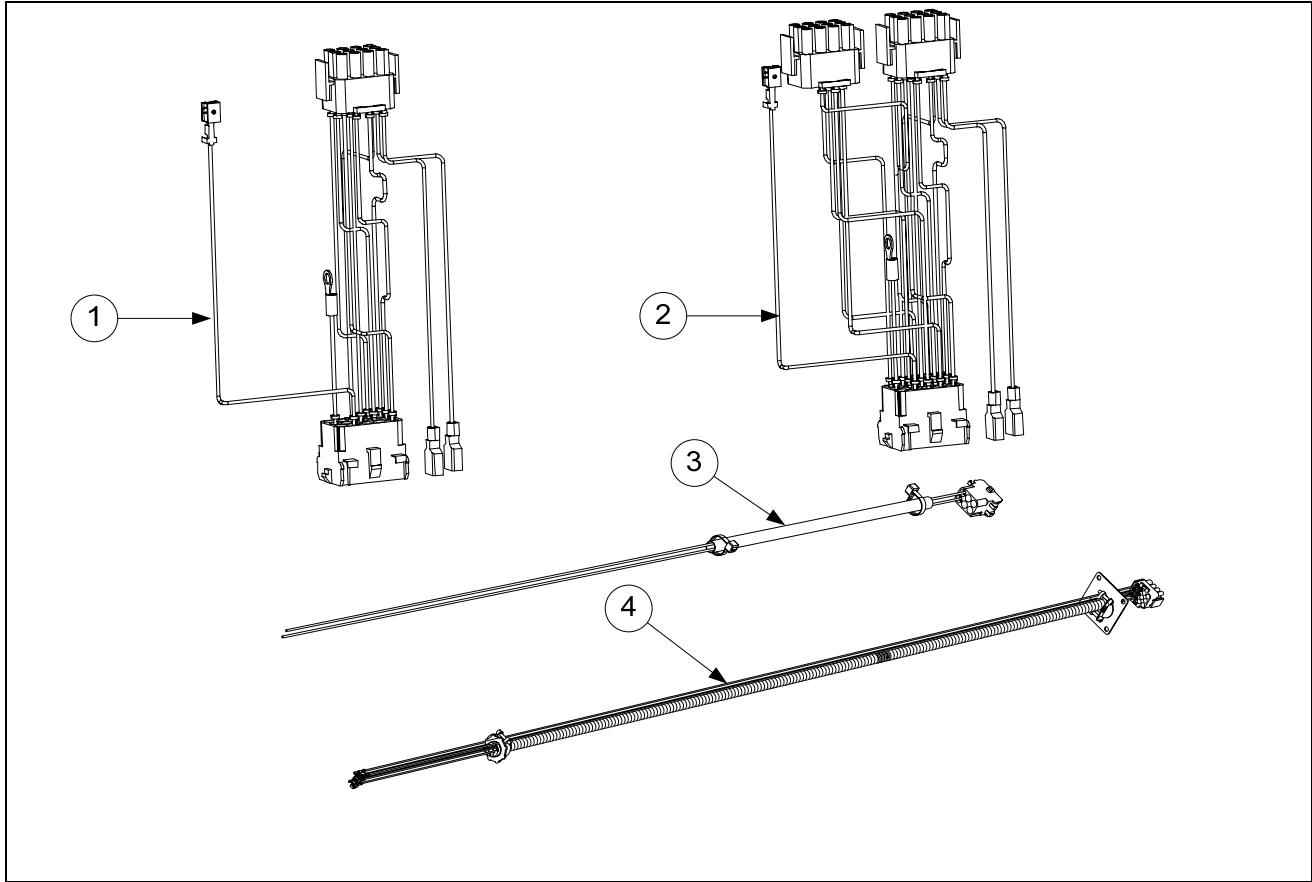

ITEM	PART #	COMPONENT
1	106-5750SP	Full Vat Control Harness J4 to J2 (<i>Standard</i>)
2	106-5751SP	Dual Vat Control Harness J4 to J1 and J2 (<i>Standard</i>)
3	108-0490SP	Filter Pump C2 to Component Box Wiring Harness
4	106-5962SP	Basket Lift Harness Assembly (<i>Standard</i>)

2.5.8.7 Component Box to Filter Pump Harness

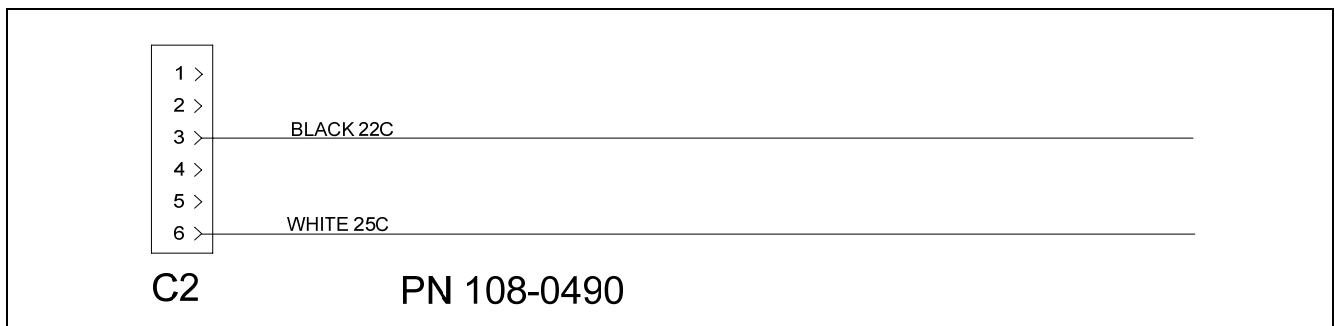

2.5.8.8 Basket Lift Harness

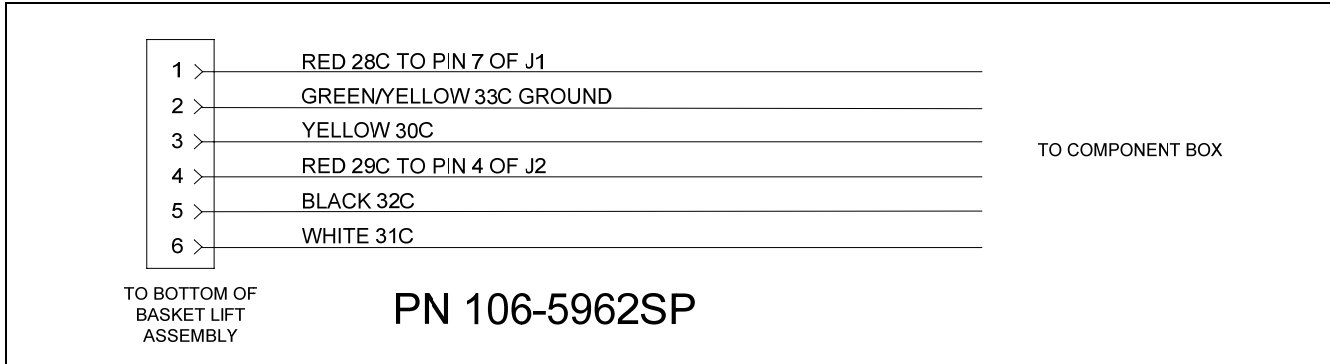

2.5.8.9 Interface Board to Controller Wiring Harness – 15-Pin

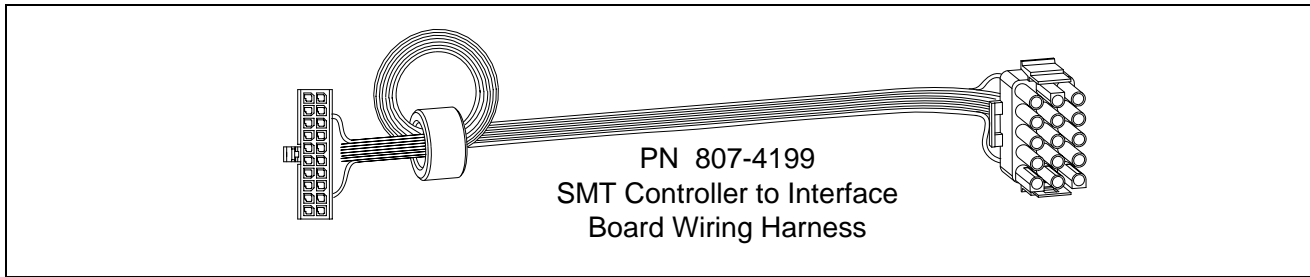

2.5.8.10 3000 and ATO Wiring Harnesses

ITEM	PART #	COMPONENT
*	807-4546	Controller Communication (<i>used from Controller to Controller</i>)
*	807-4655	Harness ATO RTD Extension (<i>used from ATO RTD to ATO Board</i>)
*	826-2569	ATO FV/DV RTD Probe Kit
*	807-4553	Harness, ATO Power (<i>used from Transformer to ATO Board</i>)
*	807-5161	Harness, ATO Solenoid, Pump Relay (<i>used from ATO Board to Top-off Pump Relay, Solenoids, and JIB Reset Switch</i>)
*	807-5162	Harness, ATO Solenoid, Pump Relay Secondary (<i>used in second ATO box on 4 battery fryers from ATO Board to Top-off Pump Relay and Solenoids</i>)
*	807-4573	Controller Locator Wire (<i>used from Controller to Interface Board</i>) See wiring diagram 805-1856 on page 1-31 for locator pin positions.
*	807-4552	Communications Terminator (<i>used on Controller pin J6 and ATO board pin J10 to terminate network</i>)
	807-4657	Jumper (<i>used on 4 and 5 battery ATO board plug J5 pin 7 and 8</i>)
*	106-9256SP	Long Top-off Power (<i>used between Component Box to ATO Box</i>)
*	807-4646	Harness, Communication Long (<i>used from Far Right Controller to ATO board</i>)
√ *	807-4660PK	SMT Pin Service Repair Kit
√ *	230-2345	SMT Pin Extractor

* Not illustrated.

√ Recommended parts.

See page 1-17 and 1-25 for Pin Positions.

2.6 Filtration System Components

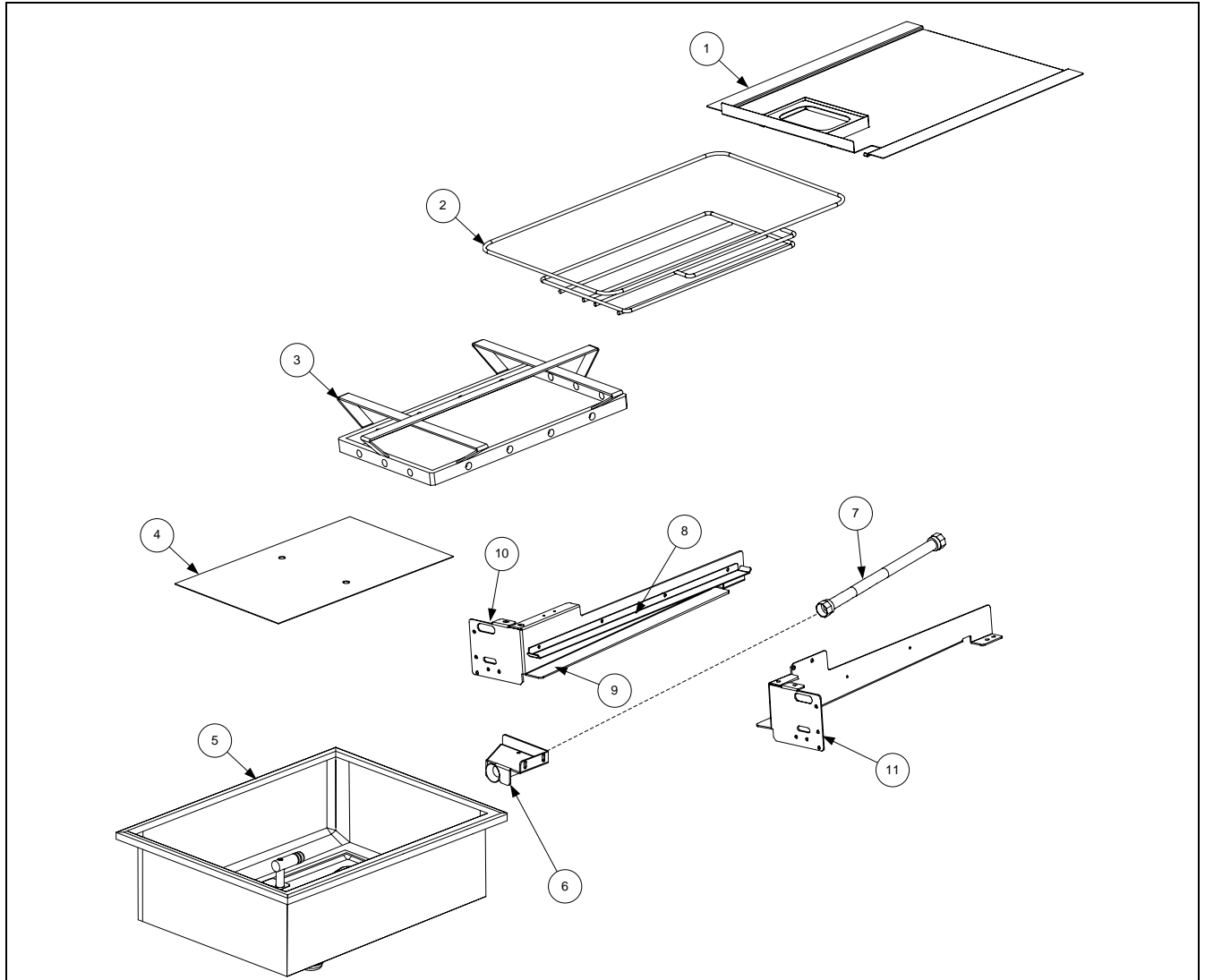

ITEM	PART #	COMPONENT
1	823-7910	Lid, Half Size Filter Pan
2	810-3288	Crumb Tray, Half Size Filter Pan
3	810-2910	Hold-Down Ring 11.20 x 19.10, Half Size Filter Pan
4	812-2024	SanaGrid Filter Screen, Half Size Filter Pan
5	106-8211SP	Pan, Half Size Filter Pan
	108-2610	Pan, Filter Single Fryer
	813-0568	Plug, 1/8-inch Socket Head Pipe (used with Item 5; two required)
√ *	826-1392	O-Ring (Pkg. of 5; used with Item 5)
6	823-6458	Suction Tube Assembly
	823-5591	Suction Tube Assembly (<i>Single Fryer Only</i>)
7	810-1055	Flexline, 11.50-inch Oil Return
8	230-6616	Rail, Upper Filter Pan Left/Right
9	230-6619	Rail, Lower Filter Pan Left/Right
10	220-3275	Support, Left Filter Pan
11	220-3710	Support, Right Filter Pan

* Not illustrated.

√ Recommended parts.

2.7 Filter Pump, Motor and Associated Components

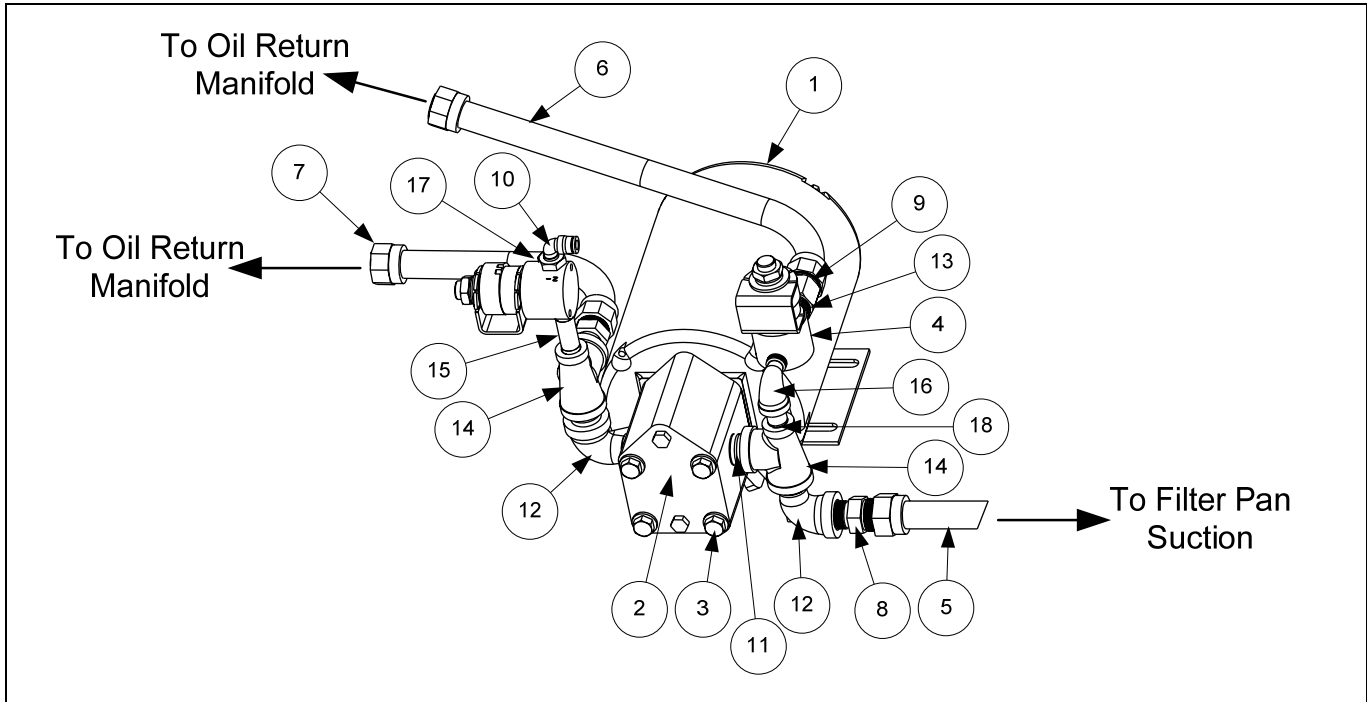

ITEM	PART #	COMPONENT
1		Motor and Gasket Kit
	826-1785	100V 50/60 Hz
√	826-1712	115V 50/60 Hz
√	826-1756	208V 50/60 Hz
	826-1270	220-240V 50/60 Hz
	826-1755	250V 50/60 Hz
2	826-1264	Pump and Gasket Kit, Viking 4 GPM (includes gasket and cap screws below)
	816-0093	Gasket, Pump/Motor
3	809-0514	Cap Screw, 5/16-inch-18 4.50" NC Hex (<i>Connects pump to motor.</i>)
*	807-11973	Viking Pump Seal Kit
*	108-0649	Heater Strip Assembly, 100-120V 25W 18"
*	106-5912	Heater Strip Assembly, 208-250V 25W 18"
4	807-2484	Valve, Solenoid 1/4-inch" NPT
5	810-1055	Flexline, 11.50-inch Oil Return
6	810-1057	Flexline, 13-inch Oil Return
7	810-1067	Flexline, 8.5-inch Oil Return
8	810-1668	Adapter, 5/8-inch to 1/2-inch NPT Male
9	810-1669	Adaptor, Female 7/8-inch OD x 1/2-inch
10	810-2493	Fitting, 1/4-inch x 90° Quick Connect Tube
*	811-1071	Tubing, 1/4-inch OD Teflon Vent (sold by the foot)
11	813-0022	Nipple, 1/2-inch x Close NPT BM
12	813-0165	Elbow, ST 1/2-inch x 1/2-inch NPT 90° BM
13	813-0304	Bushing, 1/2-inch x 1/4-inch BM Flush
14	813-0530	Tee, Reducing 1/2-inch x 1/4-inch x 1/2-inch
15	813-0537	Nipple, 1/4-inch x 2-inch NPT BM
16	813-0543	Elbow, Street 1/4-inch NPT BM
17	813-0807	Bushing, 1/4-inch NPT x 1/8-inch NPT SS
18	813-0838	Nipple, 1/4-inch NPT BM Close

* Not illustrated.

√ Recommended parts.

2.8 Frypot Assemblies and Associated Parts

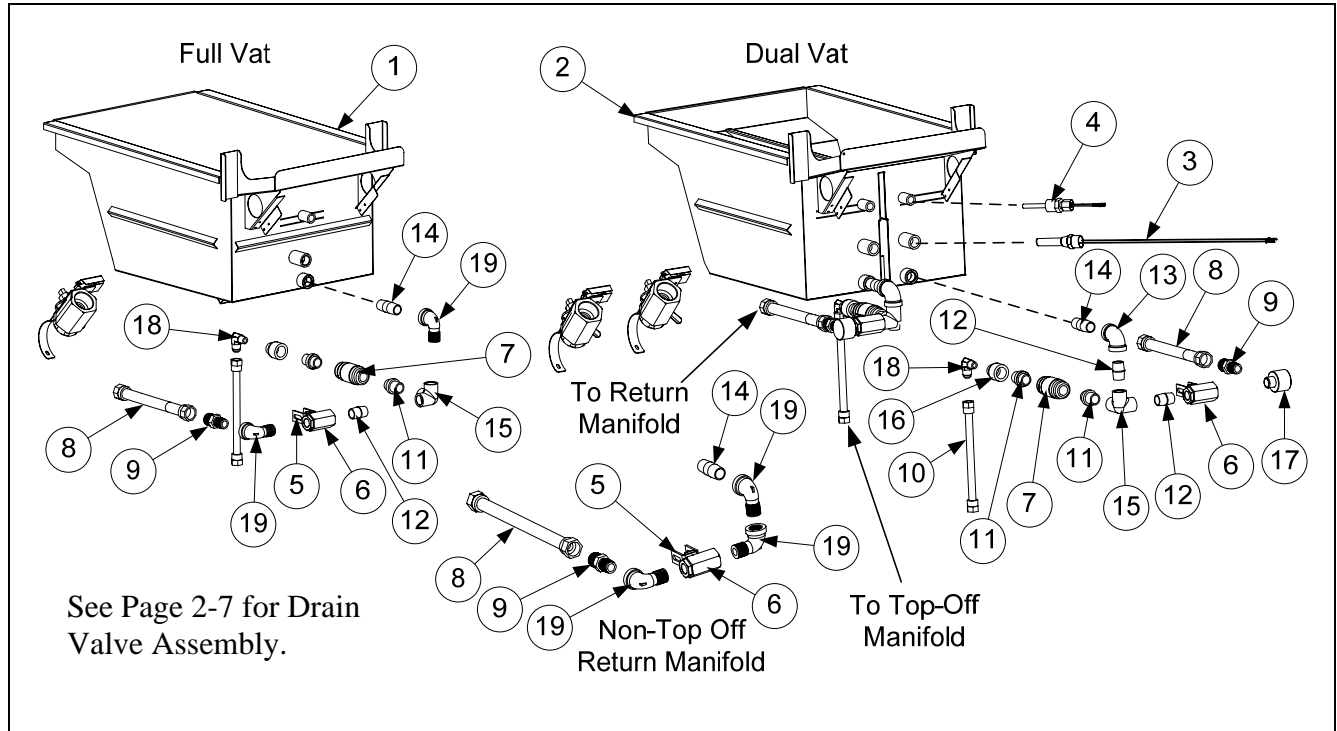

ITEM	PART #	COMPONENT
1	823-7889	Frypot, Full-Vat OCF with top off
	823-7886	Frypot, Full-Vat OCF no top off
	823-8017	Frypot, Full-Vat OCF no top off and no filtration
2	823-8060	Frypot, Dual-Vat OCF with top off
	823-8059	Frypot, Dual-Vat OCF no top off
	823-8061	Frypot, Dual-Vat OCF no top off and no filtration
	824-2210	Riser, DV Frypot
3		Thermostat Assembly, High-Limit Standard
	826-2454	Non-CE Full Vat 425°F (218°C) (14 and 17kW FV) (Color Coded Black 806-7543)
	826-2456	Non-CE Full Vat 435°F (224°C) (17kW and 14kW DV) (Color Coded Red 806-8035)
	826-2455	CE Full Vat 415°F (213°C) (14kW and 17kW CE) (Color-Coded Yellow 806-8132)
4	826-2569	Probe, Temperature ATO RTD Kit
5	200-5438	Handle, Valve Rear Flush
*	900-2935	Retainer, Nut Oil Return Valve
6	810-0278	Valve, Return ½" Ball
7	810-0667	Valve, Check ½" 1 PSI
8	810-1067	Flexline, ⅝" OD x 8.50" Long Return Oil
9	810-1668	Adaptor, Male ⅝" OD x ½"
10	810-3591	Flexline, ½" OD x 8.00" Long Top Off
11	810-3738	Adaptor, Check Valve Close NPL
12	813-0022	Nipple, ½" Close NPT BM
13	813-0062	Elbow, ½" BM x 90°
14	813-0298	Nipple, ½" x 2.00" NPT BM Pipe
15	813-0331	Elbow, V-Side Outlet ½" NPT
16	813-0555	Reducer, Bell ½" to ¼" NPT BM
17	813-0908	Adapter, ½" NPT 90° (also used in DV non-Top Off manifolds in place of item 19)
18	813-0940	Elbow, ¼" NPT x ⅜" Flare
19	813-0165	Elbow, St ½" x ½" NPT 90° BM

* Not illustrated.

√ Recommended parts.

2.9 Oil Return System Components

Typical Rear-Flush Oil Return Plumbing

Full-vat rear-flush plumbing is shown on the left side of the oil return manifold; dual-vat plumbing is shown on the right side. Plumbing for a two-fryer battery is illustrated, most of the components except the oil return manifold and a few fittings are the same regardless of the number of fryers in the battery. Return valve assemblies are shown on preceding page.

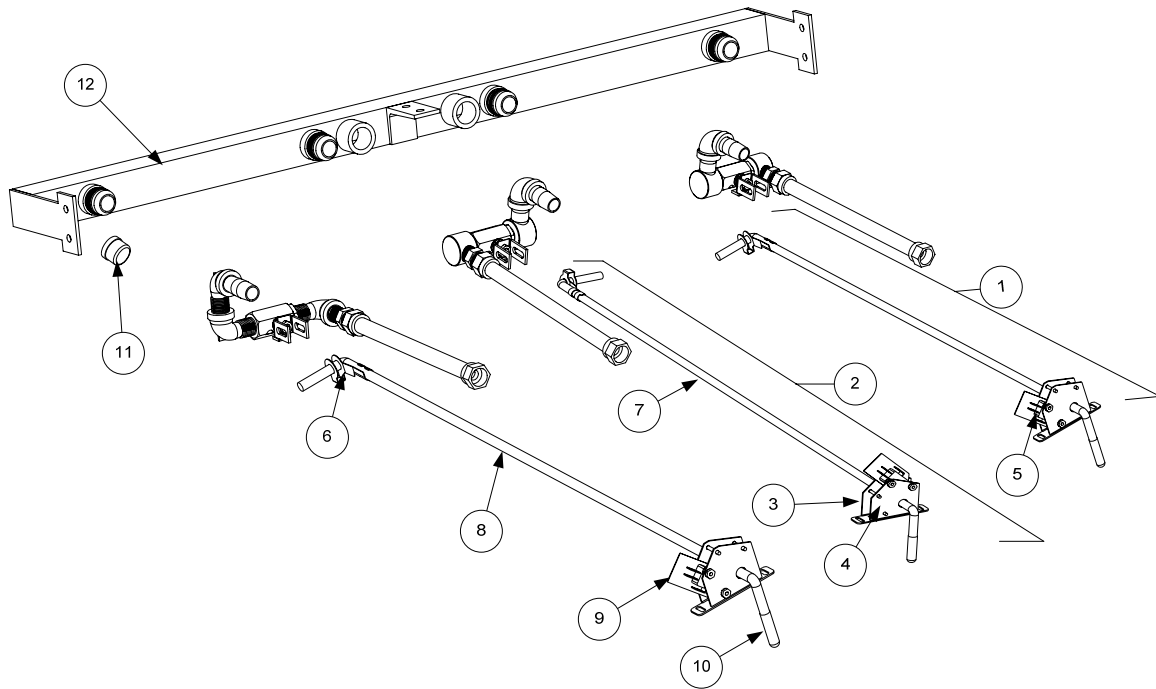

ITEM	PART #	COMPONENT
1	108-2433	Handle Assembly, Full-Vat and Right Dual-Vat Rear Flush Complete
2	108-2432	Handle Assembly, Left Dual-Vat Rear Flush Complete
3	106-5595	Bracket Assembly, Microswitch
4	200-5401	Bracket, Handle Retainer
5	807-2103	Microswitch, Straight Lever
6	809-0601	Clip, Clevis
7	810-3887	Handle, Oil Return Left Dual Vat Rod
8	810-3886	Handle, Oil Return Right Dual Vat and Full Vat Rod
9	816-0220	Insulation, Oil Return Microswitch
10	816-0643	Grip, Oil Return Valve Handle
11	813-0907	Cap, 15/16-inch Valve Safety
12		Manifolds
*	810-3015	Manifold, Two-Station Fryer (<i>use 810-2543 for non-filter units</i>)
*	810-3016	Manifold, Three-Station Fryer (<i>use 810-2544 for non-filter units</i>)
*	810-3017	Manifold, Four-Station Fryer (<i>use 810-2545 for non-filter units</i>)

* Not illustrated.

2.10 Auto Top-Off Components

2.10.1 JIB Basket and Automatic Top-Off Board Assembly

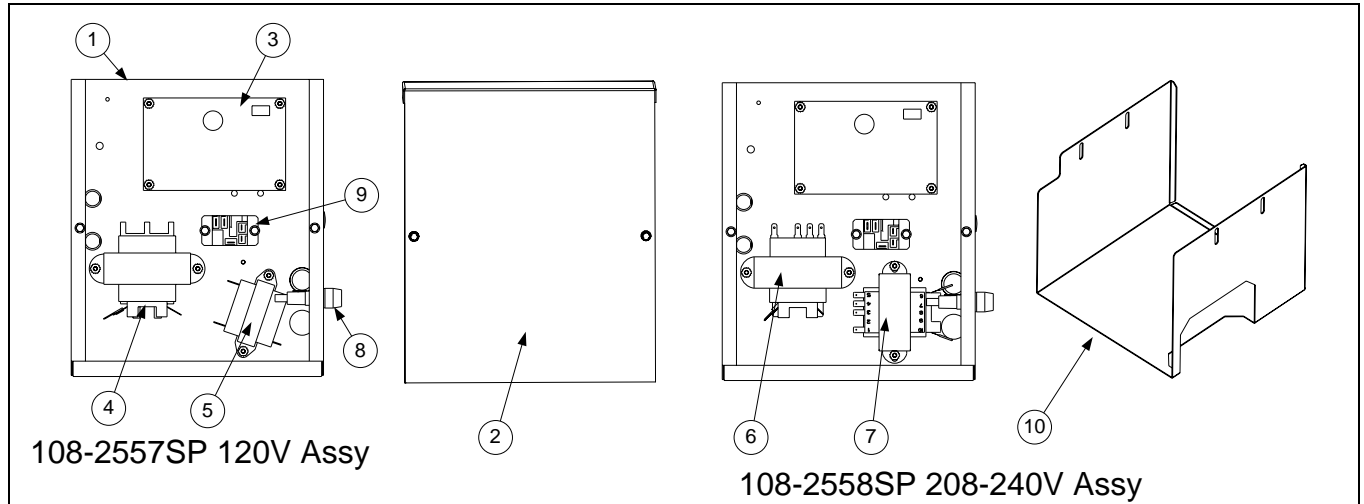

ITEM	PART #	COMPONENT
1	108-2556	Box, Assembly Auto Top Off Board
2	220-5679	Cover, Top Off Board Box
√ 3	108-2805	PCB Board, Automatic Top Off OCF
√ 4	807-2181	Transformer, 100-120V/24V 62VA
√ 5	807-0855	Transformer, 120V 50/60-12V 20VA
√ 6	807-2180	Transformer, 208-240V/24V 50VA
√ 7	807-2191	Transformer, 208/230/240 -12V 30VA
8	807-1321	Holder, Fuse AGC Panel Mount 1/4"
√ *	807-1597	Fuse, 3A Slow-Blow
√ 9	807-1683	Relay, 15AMP 120V 24V Coil (Top off pump)
10	220-8363	Cradle, JIB

* Not illustrated.

√ Recommended parts.

NOTE: Top off boxes for vats 4 and 5 have either item 4 or item 6, both have item 3.

2.10.2 JIB Cap and Pick Up Assembly

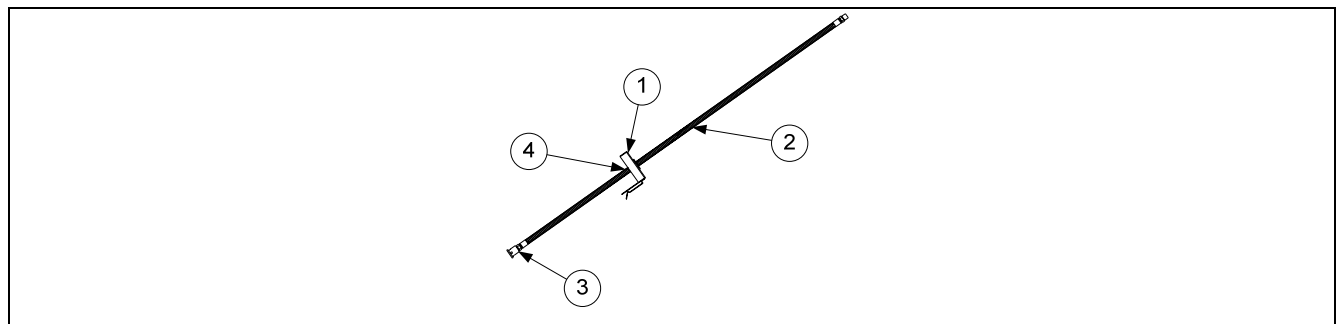

ITEM	PART #	COMPONENT
	108-1049SP	Cap, JIB Assembly (use 106-9495SP for Intl. BIB)
1	823-7575	Cap, JIB (use 823-6812 for Intl. BIB)
2	810-3663	Hose, JIB
3	810-3300	Inlet, Oil Reservoir Tube
4	810-3664	Bushing, Heyco

2.10.3 ATO Pump Assembly

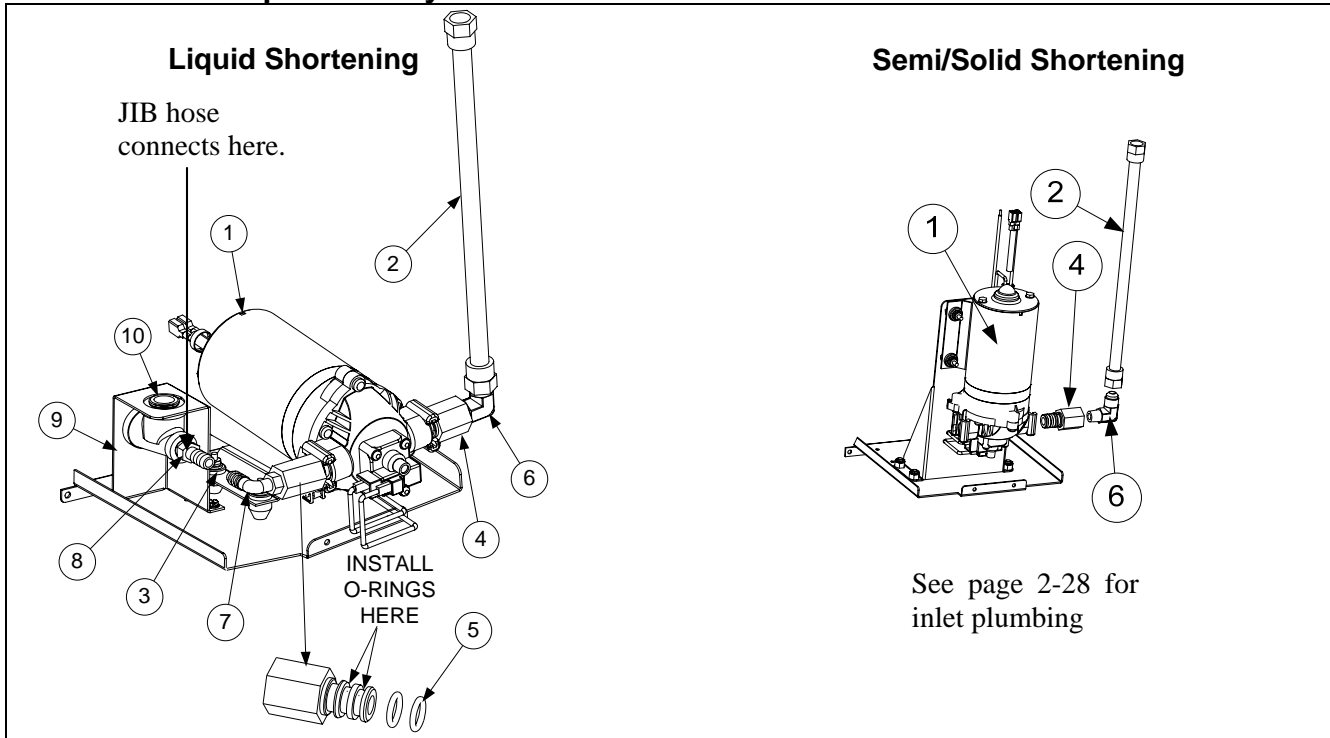

ITEM	PART #	COMPONENT
√ 1	108-0639	Pump, Shurflo 24VAC
2	810-3375	Flexline, 1/2" OD x 17-inch (Out to top off manifold)
3	811-1139	Hose, Silicone Braided (sold by the foot)
4	810-3578	Fitting, Shurflow Pump OCF
5	816-0782	O-Ring, Viton #111
6	813-0940	Elbow, 1/4" NPT x 3/8 Flare
7	816-0710	Fitting, 1/4" NPT x 1/2" Barb
8	816-0708	Fitting, 1/4" NPT Male Barb
9	823-7411	Bracket, JIB Elbow
10	813-0304	Bushing, 1/2" x 1/4" BM Flush

√ Recommended parts.

2.10.4 ATO Top-Off Manifolds

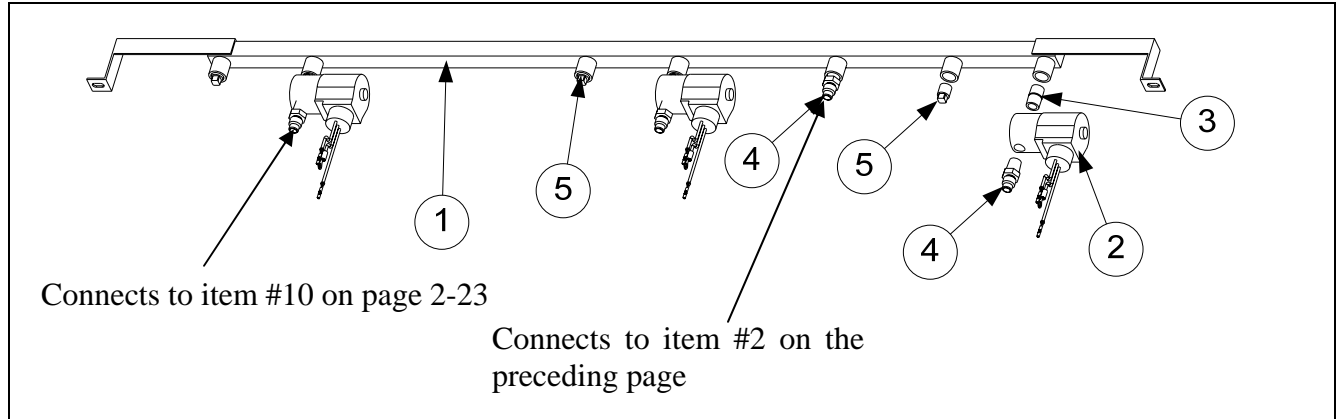

ITEM	PART #	COMPONENT
1	810-3896	Manifold, Top-Off Two Station Fryer
	810-3897	Manifold, Top-Off Three Station Fryer
	810-3898	Manifold, Top-Off Four Station Fryer
√ 2	108-2555	Solenoid Top-Off
3	810-0838	Nipple, 1/4" NPT BM Close
4	810-3270	Fitting, 3/8" Flare x 1/4" NPT
5	813-0640	Plug, 1/4" Square Head

√ Recommended parts.

2.10.5 Shortening Melting Unit

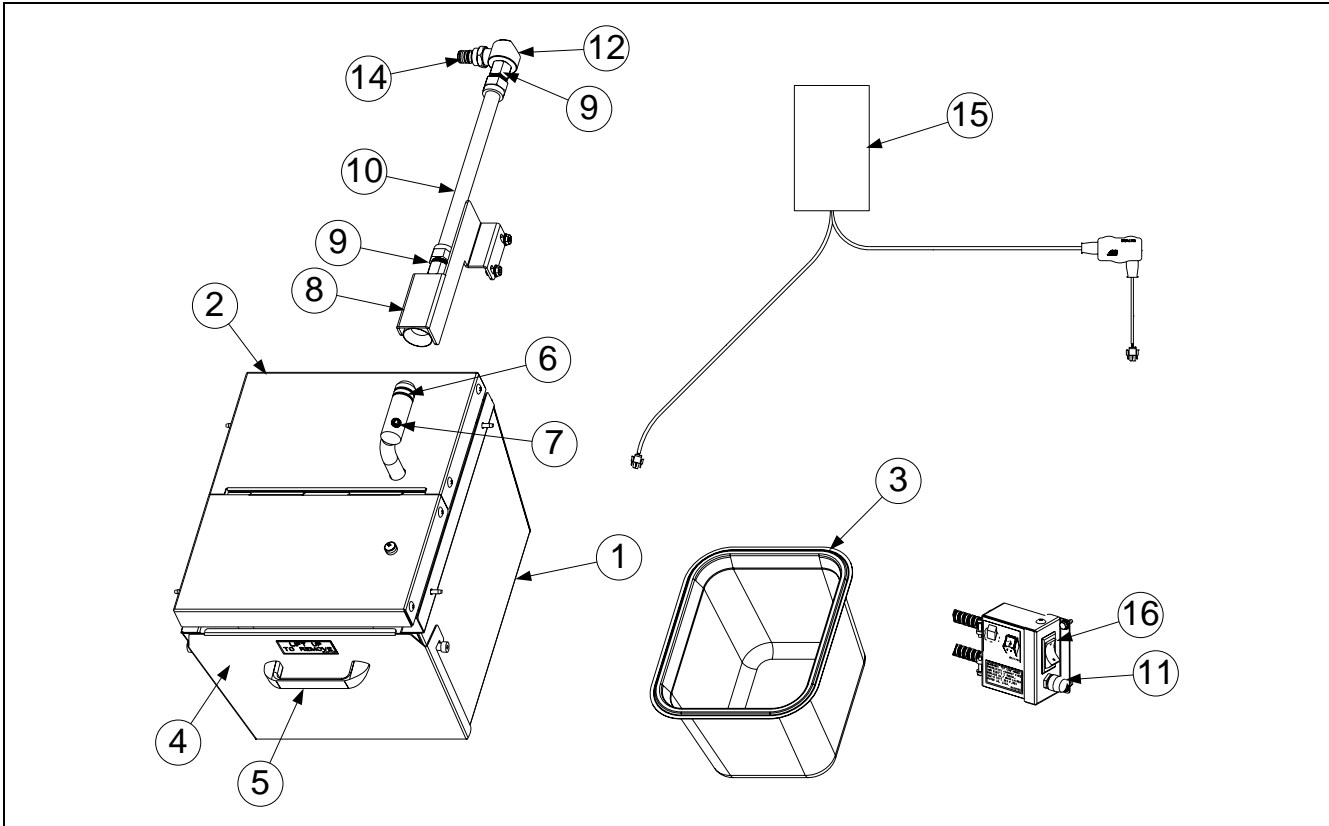

ITEM	PART #	COMPONENT
	108-3406	Assembly, Heated Shortening
1	108-2983	Box Assembly, Heated Shortening
2	108-3001	Assembly, Heated Shortening Lid
3	810-3957	Pan, Heated Shortening
4	108-3372	Cover, Shortening Box Front
5	810-0180	Handle
√ 6	826-1392	O-Ring (Pkg. of 5)
7	813-0568	Plug, 1/8-inch Socket Head Pipe
8	823-8079	Bracket W/A, Shortening Suction 3 battery
	823-8147	Bracket W/A, Shortening Suction 4 battery
9	810-1669	Adaptor, Female 7/8" OD x 1/2"
10	810-1055	Flexline, 5/8" OD x 11.5-inch
11	807-1321	Holder, Fuse
*	807-1555	Fuse 5 Amp 240V (<i>use 807-2799 for 10Amp fuse 120V</i>)
12	813-0908	Adaptor, 1/2" NPT 90°
13	810-3820	Fitting, Quick Connect Shurflo Pump
14	816-0782	O-Ring, Viton #111
15	807-5268	Strips, Hot Box Heater with controller 240V (<i>use 807-5321 for 120V</i>)
16	807-4036	Switch
*	807-1098	Heater Strip Assembly, 240V, 25W 18" (<i>use 807-1105 for 120V</i>)
*	807-1419	Heater Strip Assembly, 240V, 45W 36" (<i>use 807-1420 for 120V</i>)
*	807-1473	Heater Strip Assembly, 240V, 70W 56" (<i>use 807-1472 for 40W 120V</i>)

* Not illustrated.

√ Recommended parts.

2.10.6 Bulk Oil Relay Box and Switch

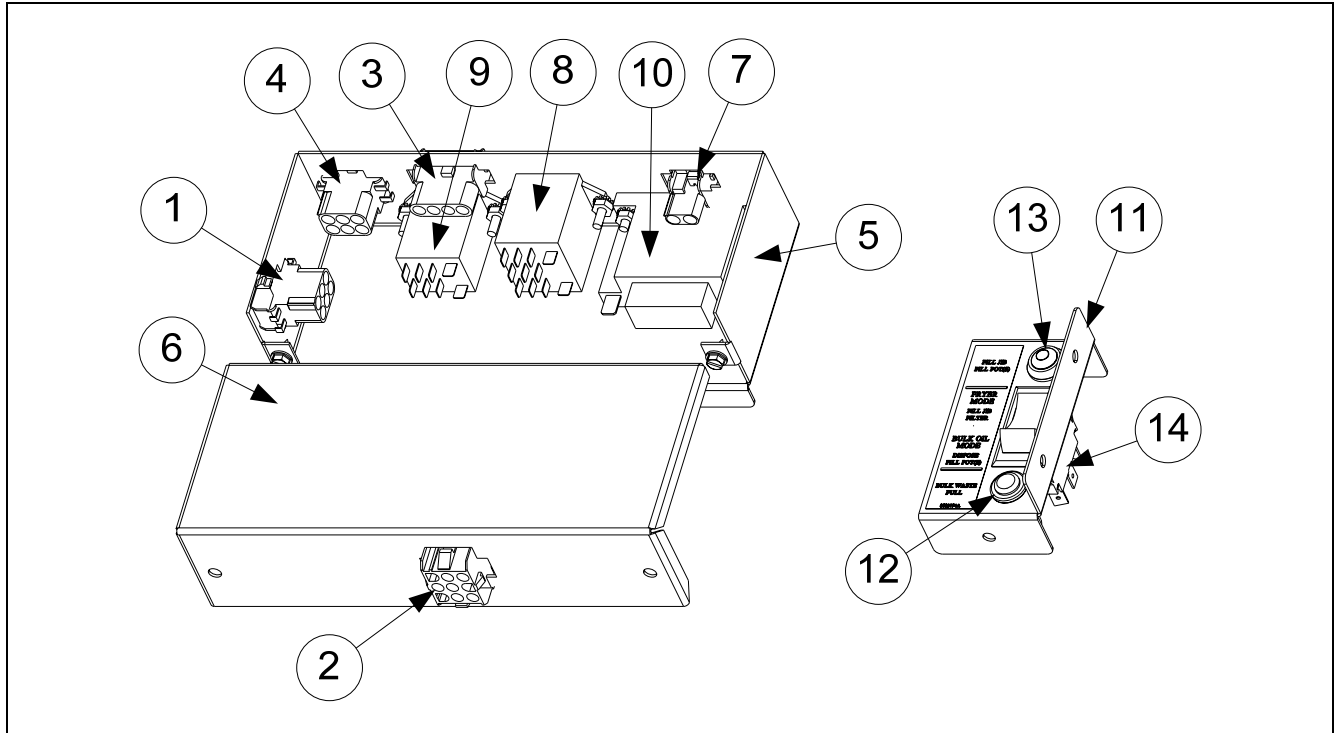

ITEM	PART #	COMPONENT
1	108-3409	Harness, Bulk Oil Power
2	108-3410	Harness, Bulk Oil Control
3	108-3412	Harness, Bulk Oil Switches
4	108-3413	Harness, Bulk Oil Communication
5	220-8665	Box, Bulk Oil Relay
6	220-8666	Cover, Bulk Oil Relay Box
7	807-1068	Connector, 2-pin
√ 8	807-5303	Relay, 24VAC 3PDT
√ 9	807-5304	Relay, 24VAC DPDT
√ 10	807-5310	Relay, 2 Second Time Delay
11	220-8706	Bracket, OCF Bulk Oil Control
12	807-5309	Light, Amber, 24VAC
√ 13	807-4678	Switch, Momentary
√ 14	807-5308	Switch, 3 Position
*	826-2987	Kit, Bulk Oil 2-Battery for fryers without bulk oil installed
*	826-2988	Kit, Bulk Oil 3-Battery for fryers without bulk oil installed

* Not illustrated.

√ Recommended parts.

2.10.7 Bulk Oil Plumbing

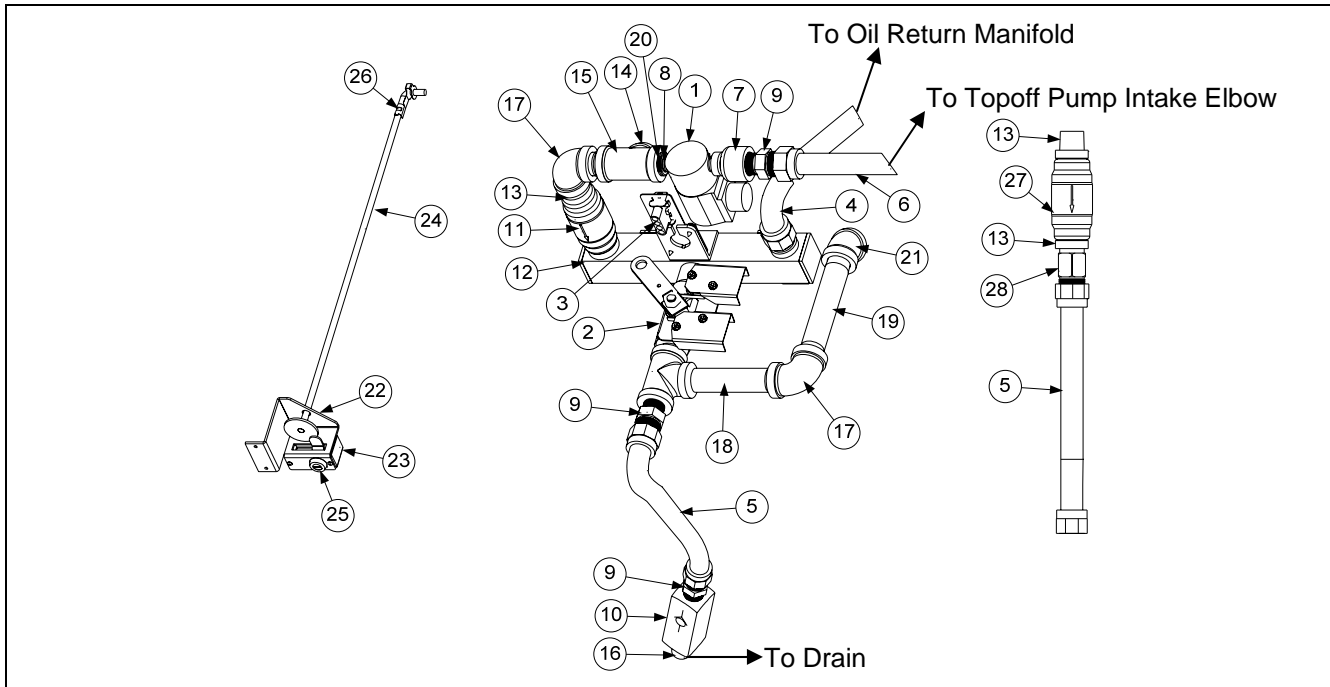

ITEM	PART #	COMPONENT
√ 1	106-6830	Solenoid Assy
2	108-3368	Valve, Assy Waste Dispose (see next page for valve assembly)
3	807-5318	Cable, Bulk Oil Communication
4	810-1057	Flexline, 5/8" OD x 13.00"
5	810-1067	Flexline, 5/8" OD x 8.50"
6	810-1069	Flexline, 5/8" OD x 29.50" 3, 4 and 5 battery (use 810-1057 for two battery)
7	810-0555	Reduce, Bell 1/2" to 1/4" NPT
8	813-0838	Nipple, 1/4" NPT
9	810-1668	Adaptor, Male 5/8" OD x 1/2"
√ 10	810-3531	Valve, Check 20 PSI (Bypass)
√ 11	810-3583	Valve, Check 4 PSI (Manifold)
12	810-3596	Manifold
13	800-3738	Adapter, Check Valve
14	813-0463	Plug, Counter Sink
15	813-0003	Tee, 1/2" x 1/2" x 1/2"
16	813-0022	Nipple, 1/2" x Close NPT
17	813-0062	Elbow, 1/2" 90°
18	813-0093	Nipple, 1/2" x 4.00"
19	813-0281	Nipple, 1/2" x 5.00"
20	813-0304	Bushing, 1/2" x 1/4"
21	813-0345	Elbow, 1/2" 45°
22	220-5656	Brace, Handle
23	220-5657	Cover, Handle
24	823-7142	Handle, Waste Pull
25	810-3587	Lock and Key, Waste Handle
26	809-0601	Clip, Clevis Left Rod End
√ 27	810-0667	Valve, Check 1 PSI (Pump Motor)
28	810-1669	Adapter, Female 7/8" OD x 1/2"

* Not illustrated.

√ Recommended parts.

2.10.8 Bulk Oil Dispose Waste Valve

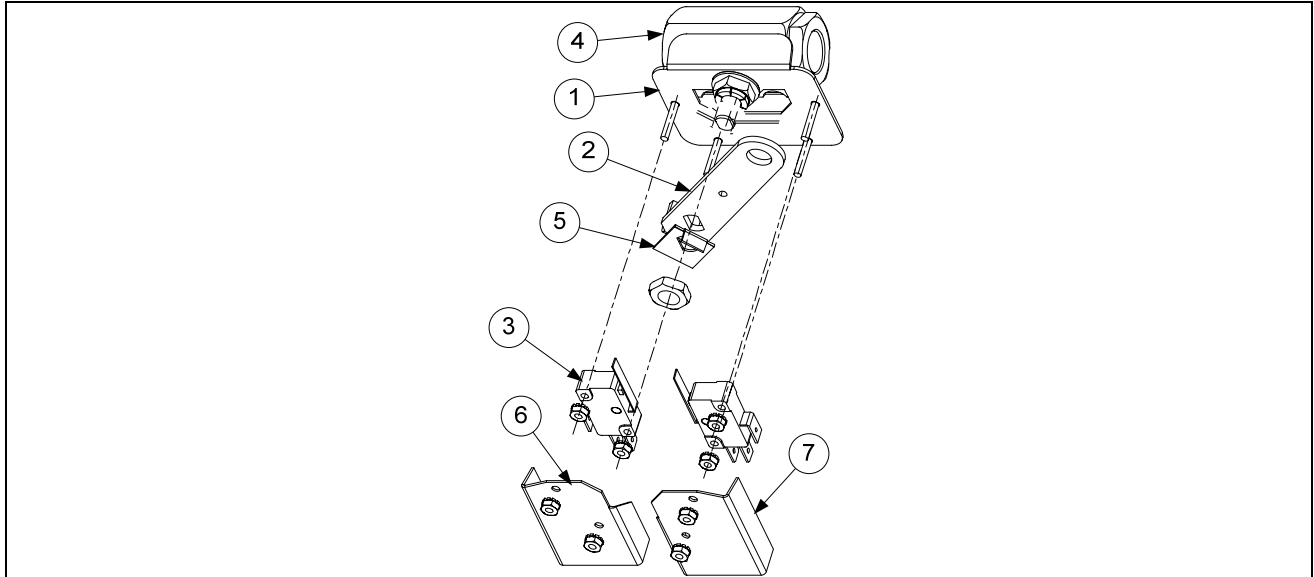

ITEM	PART #	COMPONENT
	108-3368	Valve, Dispose Waste Assembly
1	108-0445	Bracket, Waste Valve
2	220-5615	Handle, Waste Valve
√ 3	807-2103	Microswitch
4	810-0278	Valve, ½" Ball
5	900-2935	Retainer, Nut Return Valve
6	901-2348	Cover, DV Safety Switch
7	902-2348	Cover, DV Safety Switch

2.11 Wiring Connectors, Pin Terminals, and Power Cords

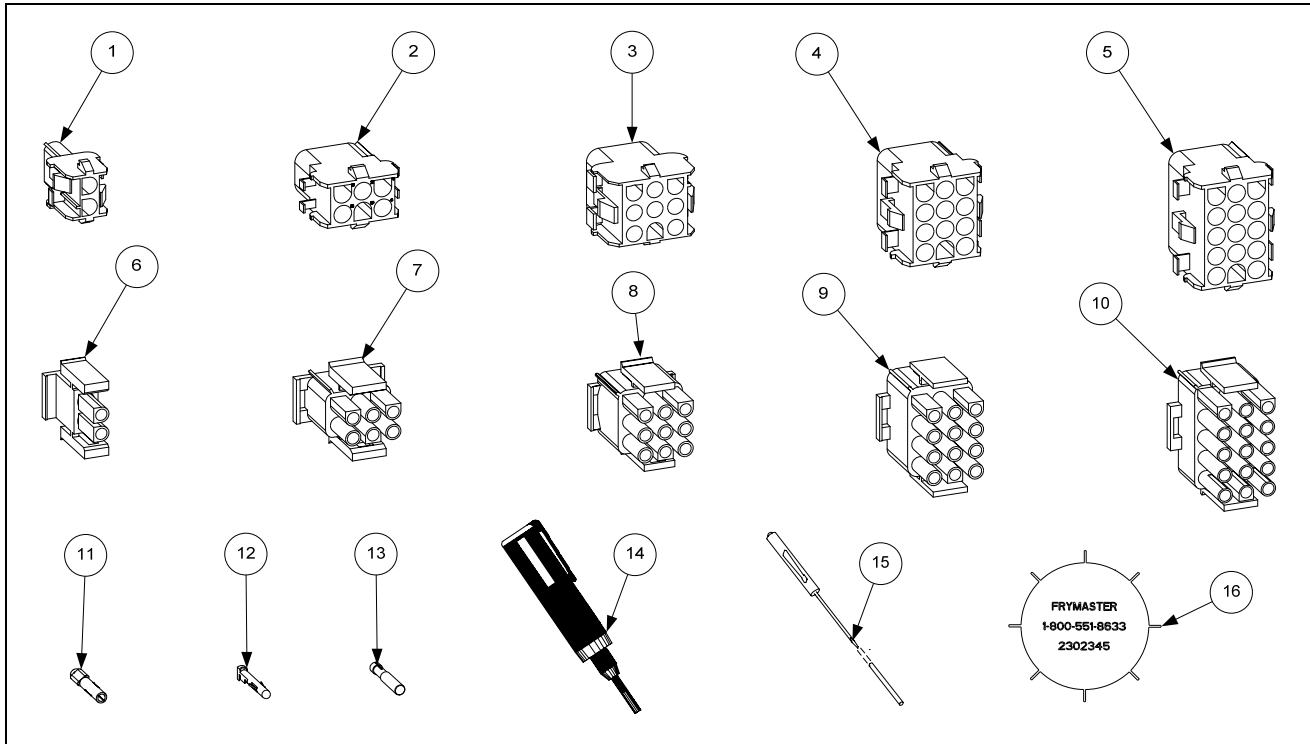

ITEM	PART #	COMPONENT
Power Cords		
*	807-0154	100/120V–15A 3-wire, w/grounded plug
*	807-1685	100/208/240V–18A 3-wire, w/o plug
*	807-3817	208-250V/74A 3-Phase 4-wire w/plug 96” 8 awg
*	807-4668	208-250V/84A 3-Phase 4-wire w/plug 96” 6 awg
*	807-3834	208-250V/84A 3-Phase 4-wire w/plug 96” 6 awg
*	807-3428	220V/15A 3-wire, w/o plug Export 96” 8 awg
*	807-3836	240V/32A 3-Phase 5-wire w/plug Export 86.5”
*	807-3835	220-250V 3-Phase 4-wire w/o plug Export 92”
*	807-3867	220-250V/50A 3-Phase 5-wire w/plug Export 109”
Connectors		
1	807-1068	2-Pin Female
2	807-0158	6-Pin Female
3	807-0156	9-Pin Female
5	807-0159	12-Pin Female
5	807-0875	15-Pin Female
6	807-1067	2-Pin Male
7	807-0157	6-Pin Male
8	807-0155	9-Pin Male
9	807-0160	12-Pin Male
10	807-0804	15-Pin Male
11	826-1341	Terminal, Female Split Pin (Pkg of 25)
12	826-1342	Terminal, Male Split Pin (Pkg of 25)
13	807-2518	Plug, Mate-N-Lock (Dummy Pin)
14	807-0928	Extract Tool Pin Pusher
15	806-4855	Pin Pusher Screwdriver Assembly
16	230-2345	SMT Pin Extractor
*	807-4660PK	SMT Pin Service Repair Kit

* Not illustrated.

2.12 Fasteners

ITEM	PART #	COMPONENT
*	809-0429	Bolt, ¼-inch – 20 x 2.00-inch Hex Head ZP Tap
*	809-0131	Bolt, ¼-inch -20 x ¾-inch Hex
*	809-1020	Cap Screw, 5/16-inch-18 5.50" NC Hex (<i>Connects pump to motor.</i>)
*	809-0448	Clip, Tinnerman
*	826-1366	Nut, 4-40 Keps Hex (Pkg. of 25) (809-0237)
*	826-1358	Nut, 6-32 Keps Hex (Pkg. of 25) (809-0049)
*	809-0247	Nut, 8-32 Keps Hex
*	826-1376	Nut, 10-32 Keps Hex (Pkg. of 10) (809-0256)
*	809-0766	Nut, 10-32 Keps Hex SS
*	809-0581	Nut, ½ NPT Locking
*	809-0020	Nut Cap 10-24 NP
*	826-1372	Nut Grip ¼-inch ¼-20 Hex NP (Pkg. of 10) (809-0059)
*	809-0417	Nut Flange ¼-inch ¼-20 Serr
*	809-0535	Nut, "T" ¼-inch-20 x 7/16 SS
*	809-0495	Nut, ¼-inch – 20 Press
*	809-0540	Nut, Lock ½-inch-13 Hex 2-Way ZP
*	826-1359	Screw, 4-40 x ¾-inch Slotted Round Head (Pkg. of 25) (809-0354)
*	826-1365	Screw, 6-32 x ⅜-inch Slot Head (Pkg. of 25) (809-0095)
*	809-0357	Screw, 6 x ⅜-inch Phillips Head NP
*	809-0359	Screw, 8 x ¼-inch Hex Washer Head
*	809-0360	Screw, 8 x ⅜-inch Hex Washer Slot Head
*	826-1371	Screw, 8 x ½-inch Hex Head ZP (Pkg. of 25) (809-0361)
*	809-0364	Screw, 8 x ⅝-inch Hex Washer Head ZP
*	809-0518	Screw, 8-32 x ⅜-inch Hex Washer Slotted Head SS
*	809-0104	Screw, 8-32 x ½-inch Slotted Head ZP
*	826-1363	Screw, 8-32 x ½-inch NP (Pkg. of 25) (809-0103)
*	826-1360	Screw, 10-24 x 5/16-inch Round Slot Head ZP (Pkg. of 25) (809-0024)
*	826-1330	Screw, 10-32 x ⅜-inch Slot Head SS (Pkg. of 25) (809-0117)
*	809-1003	Screw, 10-32 x ⅜-inch Hex Trim Head SS
*	809-0270	Screw, 10-32 x ½-inch Phillips Head ZP
*	826-1375	Screw, 10-32 x ¾-inch Hex Trim Head SS (Pkg. of 5) (809-0401)
*	809-1000	Screw, 10-32 x 1¼-inch Hex Sck C/S
*	826-1374	Screw, 10 x ½-inch Hex Head (Pkg. of 25) (809-0412)
*	809-0266	Screw, 10 x ½-inch Phillips Head ZP
*	809-0434	Screw, 10 x ⅜-inch Hex Washer Head NP
*	809-0123	Screw, 10 x ¾-inch Slot Head
*	826-1389	Screw, 1/4-20 x ¾-inch Hex Head ZP (Pkg. of 10) (809-0131)
*	809-0582	Washer ½ NPT Locking
*	809-0184	Washer, #10 LK ZP
*	809-0190	Washer, .625 X .275 X 40 Flat SS
*	809-0191	Washer, Lock ¼ Spring ZP
*	809-0193	Washer, Flat ¼ Nylon
*	809-0194	Washer, Flat 5/16 ZP

THIS PAGE INTENTIONALLY LEFT BLANK



Frymaster, L.L.C., 8700 Line Avenue, Shreveport, Louisiana 71106

TEL 1-318-865-1711 FAX (Parts) 1-318-219-7140 FAX (Tech Support) 1-318-219-7135

PRINTED IN THE UNITED STATES

SERVICE HOTLINE
1-800-551-8633

819-6686
MARCH 2012